



Service Manual

Lexmark LaserPrinter

4039-1XX

- ***Table of Contents***
- ***Start Diagnostics***
- ***Safety and Notices***
- ***Trademarks***
- ***Index***
- ***Manuals Menu***

LEXMARK™

Lexmark and Lexmark with diamond design are trademarks of Lexmark International, Inc., registered in the United States and/or other countries.

Second Edition (June 1996)

The following paragraph does not apply to the United Kingdom or any country where such provisions are inconsistent with local law: LEXMARK INTERNATIONAL, INC. PROVIDES THIS PUBLICATION "AS IS" WITHOUT WARRANTY OF ANY KIND, EITHER EXPRESS OR IMPLIED, INCLUDING, BUT NOT LIMITED TO, THE IMPLIED WARRANTIES OF MERCHANTABILITY OR FITNESS FOR A PARTICULAR PURPOSE. Some states do not allow disclaimer of express or implied warranties in certain transactions, therefore, this statement may not apply to you.

This publication could include technical inaccuracies or typographical errors. Changes are periodically made to the information herein; these changes will be incorporated in later editions of the publication. Improvements or changes in the products or the programs described in this publication may be made at any time. Publications are not stocked at the address given below; requests for publications should be made to your point of purchase.

A form for reader's comments is provided at the back of this publication. If the form has been removed, comments may be addressed to Lexmark International, Inc., Department D22A/035-3, 740 New Circle Road NW, Lexington, Kentucky 40550, U.S.A. In the United Kingdom and Eire, send to Lexmark International Ltd., Marketing and Services Department, Westthorpe, Marlow Bucks SL7 3RQ. Lexmark may use or distribute any of the information you supply in any way it believes appropriate without incurring any obligation to you.

© Copyright Lexmark International, Inc. 1996
All rights reserved.

UNITED STATES GOVERNMENT RESTRICTED RIGHTS

This software and documentation are provided with RESTRICTED RIGHTS. Use, duplication or disclosure by the Government is subject to restrictions as set forth in subparagraph (c)(1)(ii) of the Rights in Technical Data and Computer Software clause at DFARS 252.227-7013 and in applicable FAR provisions: Lexmark International, Inc., Lexington, Ky 40550.

Notices and Safety Information

References in this publication to products, programs, or services do not imply that the manufacturer intends to make these available in all countries in which it operates. Any reference to a product, program, or service is not intended to state or imply that only that product, program, or service may be used. Any functionally equivalent product, program, or service that does not infringe any existing intellectual property rights may be used instead. Evaluation and verification of operation in conjunction with other products, programs, or services, except those expressly designated by the manufacturer, are the user's responsibility.

Electronic Emission Notices

Consult the following list for any emission that may apply in your country.

Federal Communications Commission (FCC) Statement

This printer has been tested and found to comply with the limits for a Class B digital device, pursuant to Part 15 of the FCC Rules. These limits are designed to provide reasonable protection against harmful interference in a residential installation. This equipment generates, uses, and can radiate radio frequency energy and, if not installed and used in accordance with the instructions, may cause harmful interference to radio communications. However, there is no guarantee that interference will not occur in a particular installation. If this equipment does cause harmful interference to radio or television reception, which can be determined by turning the equipment off and on, the user is encouraged to try to correct the interference by one or more of the following measures:

- Reorient or relocate the receiving antenna.
- Increase the separation between the equipment and receiver.
- Connect the equipment into an outlet on a circuit different from that to which the receiver is connected.
- Consult your point of purchase or service representative for additional suggestions.

The manufacturer is not responsible for any radio or television interference caused by using other than recommended cables or by unauthorized changes or modifications to this equipment. Unauthorized changes or modifications could void the user's authority to operate the equipment.

Note: To comply with FCC regulations on electromagnetic interference, for a Class B computing device, the printer cable must be shielded.

To assure compliance with FCC regulations for a Class B computing device, use a properly shielded and grounded IBM cable. Part numbers for the various interface cables are: part number 1525612 for parallel interface, and part number 8509386 for serial interface. Use of a substitute cable not properly shielded and grounded may result in violation of FCC regulations.

Industry Canada Compliance Statement

This digital apparatus does not exceed the Class B limits for radio noise emissions from digital apparatus as set out in the interference-causing equipment standard entitled: "Digital Apparatus", ICES-003 of Industry Canada.

Avis de conformité aux normes d'Industrie Canada

Cet appareil numérique respecte les limites de bruits radioélectriques applicables aux appareils numériques de Classe B prescrites dans la norme sur le matériel brouilleur : "Appareils numériques", NMB-003 édictée par Industrie Canada.

The United Kingdom Telecommunications Act 1984

This apparatus is approved under the approval number NS/G/1234/J/100003 for the indirect connections to the public telecommunications systems in the United Kingdom.

European Community (EC) Electromagnetic Compatibility Directive

This product is in conformity with the protection requirements of EC Council directive 89/336/EEC on the approximation of the laws of the Member States relating to electromagnetic compatibility.

この装置は、第二種情報装置（住宅地域又はその隣接した地域において使用されるべき情報装置）で住宅地域での電波障害防止を目的とした情報処理装置等電波障害自主規制協議会（VCCI）基準に適合しております。

しかし、本装置をラジオ、テレビジョン受信機に近接してご使用になると、受信障害の原因となることがあります。

取扱説明書に従って正しい取り扱いをして下さい。

German Statement of Acoustic Emissions

A declaration of conformity with the requirements of the Directive has been signed by the Director of Manufacturing and Technical Support, Lexmark International, Ltd., Boigny, France.

This product satisfies the Class B limits of EN 55022.

Trademarks

Lexmark is a trademark of Lexmark International, Inc.

The following terms, denoted by a double asterisk (**) in this publication, are trademarks or registered trademarks of the following companies.

AppleTalk	Apple Computer, Inc.
IBM	International Business Machines Corporation
LocalTalk	Apple Computer, Inc.
PCL	Hewlett-Packard Company
PostScript	Adobe Systems Incorporated

AppleTalk and LocalTalk are trademarks of Apple Computer, Inc. registered in the United States and other countries.

PCL is a registered trademark of the Hewlett-Packard Company. PCL 5 is Hewlett-Packard Company's designation of a set of printer commands (language) and functions included in its printer products. This printer is designed and manufactured by Lexmark International, Inc., to be compatible with the PCL 5 language. This means the printer recognizes PCL 5 commands used in various applications programs, and that the printer emulates the functions corresponding to the commands.

PostScript is a registered trademark of Adobe Systems Incorporated. PostScript is Adobe Systems' designation of a set of printer commands (language) and functions included in its software products. This printer is designed and manufactured by Lexmark International, Inc., to be compatible with the PostScript Level 2 language. This means the printer recognizes PostScript Level 2 commands used in the various application programs, and that the printer emulates the functions corresponding to the commands.

Safety Information

- The maintenance information for this product has been prepared for use by a professional service person and is not intended to be used by others.
- There may be an increased risk of electric shock and personal injury during disassembly and servicing of this product. Professional service personnel should understand this and take necessary precautions.
- The safety features of some parts may not always be obvious. Therefore, replacement parts must have the identical or equivalent characteristics as the original parts.

Sicherheitshinweise

- Die Wartungsinformationen für dieses Produkt wurden zur Verwendung durch einen Wartungsfachmann entwickelt und sollten nicht von anderen benützt werden.
- Zusätzliches Risiko eines elektrischen Schlags und körperlicher Verletzung existiert während des Auseinandernehmens und der Wartung des Geräts. Fachpersonal sollte im vollen Verständnis der Lage entsprechende Vorsichtsmaßnahmen ergreifen.
- Ersatzteile müssen gleiche oder gleichwertige Merkmale wie die Originalteile aufweisen, da Sicherheitsvorkehrungen nicht immer offensichtlich sind.

Consignes de Sécurité

- Les consignes d'entretien et de réparation de ce produit s'adressent uniquement à un personnel de maintenance qualifié.
- Le démontage et l'entretien de ce produit pouvant présenter certains risques électriques, le personnel d'entretien qualifié devra prendre toutes les précautions nécessaires.
- Les normes de sécurité de certaines pièces n'étant pas toujours explicites, les pièces de rechange doivent être identiques ou conformes aux caractéristiques des pièces d'origine.

Norme di sicurezza

- Le informazioni riguardanti la manutenzione di questo prodotto sono indirizzate soltanto al personale dell'assistenza autorizzato.
- Durante lo smontaggio e il mantenimento di questo prodotto, è possibile il rischio accresciuto di scosse elettriche e danni personali. Il personale di assistenza autorizzato, consapevole di ciò, deve adottare le precauzioni necessarie.
- È possibile che le funzioni di sicurezza di alcuni elementi non siano così ovvie, quindi, i pezzi di ricambio devono avere caratteristiche identiche o equivalenti a quelle dei pezzi originali.

Pautas de Seguridad

- La información sobre el mantenimiento de este producto fue escrita para el personal de mantenimiento cualificado y no para cualquier otro usuario.
- Existen mayores riesgos de descargas eléctricas y daños personales durante el desmontaje y la reparación de la máquina. El personal cualificado comprende esto y toma las precauciones necesarias.
- Los dispositivos de seguridad de algunas partes quizá no siempre puedan ser reconocidas a simple vista. Por lo tanto, las partes de reemplazo deben poseer características idénticas o equivalentes a las partes originales.

Sikkerhedsoplysninger

- Oplysningerne om vedligeholdelse af dette produkt er forberedt med henblik på professionelt servicepersonale, og bør derfor ikke benyttes af andre.
- Risikoen for elektrisk stød øges under demontering og service af dette produkt, hvorfor der bør tages de nødvendige forholdsregler.
- Sikkerhedsforanstaltningerne er ikke altid lige åbenbare for alle reservedele. Der bør derfor kun anvendes originale reservedele eller reservedele med samme egenskaber som de oprindelige.

Ozone Information

This product does not produce measurable amounts of ozone gas.

Preface

This manual is divided into the following chapters:

- “General Information” contains a general description of the printer and the maintenance approach used to repair it. Special tools and test equipment are listed in this chapter, as well as general environmental and safety instructions.
- “Diagnostic Information” contains error code table, symptom table, and service checks used to isolate failing field replaceable units (FRUs).
- “Diagnostic Aids” contains tests and checks used to locate or repeat symptoms of printer problems.
- “Repair Information” provides instructions for making printer adjustments and removing and installing FRUs.
- “Connector Locations” uses illustrations to identify the major components and test points on the printer.
- “Preventive Maintenance” contains safety inspection guidelines, lubrication specifications, and maintenance information to prevent problems and maintain optimum performance.
- “Parts Catalog” contains illustrations and part numbers for individual FRUs.

Table of Contents

Notices and Safety Information	iii
Electronic Emission Notices.....	iii
Federal Communications Commission (FCC) Statement	iii
Industry Canada Compliance Statement	iv
The United Kingdom Telecommunications Act 1984	iv
European Community (EC) Electromagnetic Compatibility Directive	v
German Statement of Acoustic Emissions.....	v
Trademarks	vi
Safety Information	vii
Ozone Information.....	viii
Preface	ix
Table of Contents	xi
General Information	1
Models Covered in this Manual.....	1
IBM Models	1
Lexmark Model	2
Options.....	2
Maintenance Approach	3
Abbreviations	4
Unique Tools Required For Service.....	4
Diagnostic Information	5
4039 Diagnostics: Failures With Error Codes	5
Power-On Self Test (POST).....	11
Symptom Table	12
Banding	13
Background	13
Black Page	15
Blank Page.....	16
Blurred or Fuzzy Print	17
Dead Machine	17
Duplex	18
Fan (927 Error).....	19

Fuser Theory	20
Fuser: 920, 921, or 922 Error	20
Fuser: 923 Error	21
Honeycomb	21
Horizontal Void or Streak	22
LAN Problems	23
Light Print	23
Network Card 977 Errors.....	24
Network Wrap Tests.....	24
Output Bin Sensor	24
Operator Panel Problem.....	25
Paper Feed Problem, 500-Sheet Second Tray	26
Paper Feed, Base Printer.....	26
Paper Feed, Duplex Unit.....	27
Paper Feed Problem, Envelope+ Feeder/ 100-Sheet Auxiliary Feeder.....	28
Printhead	28
Paper Size Sensing Problem	29
Regularly Spaced Marks	30
Residual Image	30
Random Marks.....	31
Skew, all edges	31
Skew, top and bottom only	31
Stalled (diamonds on display)	31
Vertical Void or Streak.....	32
Diagnostic Aids.....	33
Diagnostics Mode	33
Grouped Diagnostic Aids.....	34
Alphabetical List of Diagnostic Aids	35
Auto Clean.....	35
Auto Clean Delay	35
Auto Clean Frequency.....	35
Defaults	36
Developed Image Test	36
Disk Test/Clean.....	36
Duplex Feed 1 Test.....	37
Duplex Feed 2 Test.....	38
Envelope Enhance	39
Envelope Print Test.....	39
Error Log (“plus” machines only).....	39

Fuser Temperature And Warm-Up Time.....	40
Fuser Temperature	40
Warm-up Time	40
Maintenance Kit Count.....	41
Memory Test	41
Operator Panel Tests	41
Button Test.....	41
LCD Test.....	42
Page Count	42
Paper Feed Test	42
Permanent Page Count.....	43
Print Contrast (Transfer on “plus” machines)	43
Print Registration.....	43
Print Test Page	43
Print Tests	44
Print Test 1.....	44
Print Test 2.....	44
Print Test 3.....	45
Quick Disk Test	45
Quick Test.....	45
Sensor Test.....	46
Network Connections and Checks	47
Wrap Tests.....	47
LAN Information	48
Serial Interface Option, 10P	48
Function Switch Setting	48
Repair Information.....	53
Handling ESD-sensitive Parts	53
Adjustments	54
Envelope Restraint Spring On The Envelope+ Feeder	54
Paper Restraint Spring On The 100-sheet Auxiliary Feeder	54
Envelope Feeder Magnet And 100-sheet Auxiliary Feeder Magnet	55
Fuser Drive Gear Backlash	56
Fuser Solenoid	58
Paper Feed Magnet	59
Optional Paper Feed Magnet	60
Printhead Skew - Level 1	61
Printhead Skew - Level 2	62

Print Registration Adjustment.....	63
Removals	64
Covers	64
Right Cover Removal	64
Front Cover Removal	64
Left Cover Removal.....	66
Top Cover Removal	66
Transfer Roll Removal.....	68
D-roll Assembly Removal	69
Drive Motor Removal.....	70
Fan/Redrive Removal.....	72
Fuser Removal	74
Fuser Input Guide Removal	74
Fuser Lamp Removal	76
Fuser Solenoid Removal	77
Fuser Thermistor Removal.....	78
HVPS Removal	80
Input Sensor Removal.....	82
Lower Frame Assembly Removal	83
LVPS Removal	84
LVPS Cover Removal	85
Operator Panel Removal.....	86
Option Card Removal.....	86
Exit Sensor Removal.....	87
Paper Feed Magnet Assembly Removal.....	88
Paper Feed Rollers Removal	89
Paper Size Switch Removal	90
Printhead Removal.....	91
System Board Removal.....	92
System Cable Removal.....	94
Fuser/Sensor Cable Removal	94
Torquer Motor Removal (10P).....	94
Toner Sensor Removal	95
Transfer Roll Housing Removal	96
Upper Frame Removal	97
Zif Connector Removal.....	98
Duplex Option Top Cover And Table Cover Removal.....	99
Duplex Option Exit Card And Cover Removal.....	100
Duplex Option Bottom Cover And Entry Sensor Card Removal.....	100
Duplex Option System Card And Motor Removal	102

Connector Locations.....	103
Major Assembly Locations	103
Gear Train	104
RIP Board Installation Hardware	105
HVPS	106
Transfer Roller Housing	106
System Cable	107
System Board Connectors 10R/12R/12L	108
System Board Connectors 16L	110
System Board Connectors 10P	112
Printhead Cables.....	114
Mirror Motor Cable/Fan Cable.....	115
Operator Panel/Output Bin Sensor Cable — Handle-Mounted Outbin Sensor.....	116
Operator Panel/Output Bin Sensor Cable — Redrive-Mounted Outbin Sensor.....	117
Printer Ground Straps	119
Preventive Maintenance.....	121
Safety Inspection Guide	121
Lubrication Specifications	121
Printhead Window Cleaning Procedure	124
Cleaning The Transfer Roller	124
Scheduled Mechanical Maintenance	125
Parts Catalog.....	127
How To Use This Parts Catalog	127
Assembly 1: Covers	128
Assembly 2: Lower Frame	132
Assembly 3: Upper Frame	136
Assembly 4: Printhead	140
Assembly 5: Paper Feed.....	142
Assembly 6: Paper Feed Alignment Gears.....	146
Assembly 7: Paper Feed Drive	148
Assembly 8: Standard Paper Tray (200 sheet).....	150
Assembly 9: Paper Tray (500-Sheet).....	152
Assembly 10: Base for Paper Drawer (500-Sheet).....	154
Assembly 11: Optional Paper Drawer (500-Sheet).....	156
Assembly 12: Fuser	158
Assembly 13: Electronics.....	162
Assembly 14: Transfer Roll.....	166
Assembly 15: Duplex Option.....	168

Assembly 16: Envelope+ and 100-Sheet	
Auxiliary Feeder	170
Assembly 17: Options	172
Assembly 18: Miscellaneous	173
Index	175

General Information

The 4039 is a family of 600 dpi Laserprinters designed to attach to IBM** compatible PC's and to most types of computer networks. The printer has PostScript** and PCL** emulation standard.

Models Covered in this Manual

There are no voltage or pinout differences between the regular models and the plus models. For example, a voltage callout for the 16L also applies to the 16L plus.

IBM Models

4039-10R	10ppm PostScript Level 1 emulation, input/output capacity 200/250
4039-12R	12ppm PostScript Level 1 emulation, input/output capacity 200/250
4039-12L	12ppm PostScript Level 1 emulation, output bin sensing, input/output capacity 500/500
4039-12C	Similar to 12R, designed for printing labels and card stock
4039-16L	16ppm PostScript Level 1 emulation, output bin sensing, input/output capacity 500/500
4039-10R plus	10R with PostScript Level 2 emulation and service error log (RPQ only)
4039-12R plus	12R with PostScript Level 2 emulation and service error log
4039-12C plus	12C with PostScript Level 2 emulation and service error log (RPQ only)
4039-12L plus	12L with PostScript Level 2 emulation and service error log
4039-16L plus	16L with PostScript Level 2 emulation and service error log

Lexmark Model

4039-10 plus (Called 10P in this manual and on the serial number plate) 10ppm, PostScript Level 2 emulation, no serial port, torquer motor rather than paper pick solenoid, and service error log

Options

The following options are available. Some options are not compatible with all printer models. Some options are not available in every country. Contact your point of purchase for options available in your country.

Memory upgrade options of 2MB, 4MB and 8MB.

Flash memory options of 1MB, 2MB and 4MB

Intergated network options

Token-Ring option

Ethernet option

AppleTalk** option

200 and 500-sheet paper trays of A5, letter, and legal size.

500-sheet second drawer (withe letter-size paper tray)

Envelope+ feeder

100-sheet auxiliary

Duplex option

Font cards

Font cards adapter

40 MB Hard Disk

Serial adapter

Maintenance Approach

The diagnostic information in this manual will lead you to the correct field replaceable unit (FRU) or part. Use the error code charts, symptom index, service checks, and diagnostic aids to determine the symptom and repair the failure. See “Diagnostic Information” starting on page 5. This printer can be serviced without being connected to a host.

After you complete the repair, perform tests as needed to verify the repair.

Abbreviations

ASIC	Application-Specific Integrated Circuit
CSU	Customer Setup
DRAM	Dynamic Random Access Memory
EEPROM	Electrically Erasable Programmable Read-Only Memory
EP	Electrophotographic Process
ESD	Electrostatic Discharge
FRU	Field Replaceable Unit
HVPS	High Voltage Power Supply
LAN	Local Area Network
LASER	Light Amplification by Stimulated Emission of Radiation
LCD	Liquid Crystal Display
LED	Light-Emitting Diode
LVPS	Low Voltage Power Supply
NVRAM	Nonvolatile Random Access Memory
OEM	Original Equipment Manufacturer
PICS	Problem Isolation Charts
PIXEL	Picture Element
POR	Power-On Reset
POST	Power-On Self Test
PQET	Print Quality Enhancement Technology
RIP	Raster Image Processor
ROS	Read-Only Storage
SRAM	Static Random Access Memory
UPR	Used Parts Replacement
VAC	Volts alternating current
VDC	Volts direct current

Unique Tools Required For Service

Wrap Plug (Parallel), P/N 1319128

Wrap Plug (Serial), P/N 1329048

Twinax/serial debug cable, P/N 1381963

Coax/serial debug cable, P/N 1381964

Diagnostic Information

4039 Diagnostics: Failures With Error Codes

Two-digit codes are messages for the 4039 user, but if they recur frequently or at inappropriate times they may be symptomatic of a service problem. On “plus” models, refer to the diagnostics error log for the last six errors or paper jam codes.

Error/Code	Action
20 Paper Jam	The input sensor was not unmade in time. See “Paper Feed, Base Printer” on page 26.
21 Paper Jam	The exit sensor was not made in time after the input sensor was made. See “Paper Feed, Base Printer” on page 26.
22 Paper Jam	The exit sensor was not unmade in time. See “Paper Feed, Base Printer” on page 26.
23 Paper Jam	Jam at the duplex unit. Paper is either not leaving the duplex entry sensor in time or not making or unmaking the duplex exit sensor in time. See “Duplex” on page 18.
24 Short Paper	The defined paper size is too short to print data as formatted.
25 Incorrect Manual Feed	Paper fed manually while motor is running and previous page in path.
27 Change Envelope/Paper	Envelopes/paper loaded are wrong size.
28 Load Envelope/Paper	Input sensor not made after pick attempt. Tray is empty or printer is requesting a manual feed.
29 Output Bin Full	The output bin sensor has not been unmade.
30 Top Cover Open or Print Cartridge Missing	

Error/Code	Action
37 Insufficient Memory	Not enough memory for function requested.To verify that the printer recognizes all the installed memory, go to the user menus and print the "Print Menus" test page. Make sure the memory shown on the printout matches the installed memory.
38 Memory Full	Memory used to store pages is full.To verify that the printer recognizes all the installed memory, go to the user menus and print the "Print Menus" test page. Make sure the memory shown on the printout matches the installed memory.
39 Complex Page	Page too complex to print.To verify that the printer recognizes all the installed memory, go to the user menus and print the "Print Menus" test page. Make sure the memory shown on the printout matches the installed memory.
43 Font Card Not Supported	Font card format not supported by printer.
44 Defective Font Card	Defective font card installed in font slot.
47 Font Card Removed While Printing	Printer needs data on removed card.
52 Flash Full	Not enough flash memory for data requested to be stored.
53 Unformatted or Defective Flash	Flash problem at POR or while attempting to write.
54 Serial Error	Framing or parity error on serial.
58 Duplex Not Attached	Duplex is electrically connected but no longer mechanically attached, and printer top cover is closed.
59 Duplex Cover Open	Top cover of duplex unit is sensed open.
62 Disk Full	Not enough disk space for data that has been requested to be written to disk.

Error/Code	Action
63 Unformatted or Defective Disk	The printer will ignore a disk it senses as defective. Run the Quick Disk Test. If the test fails, the disk is defective or the data on track1 is bad. If the Quick Disk Test passes but the disk does not work, run the Disk Test/Clean (2 hr. test). Replace the disk if instructed by the operator panel.
7X Network Card Codes	These user codes are documented in various network card user manuals. See "Network Wrap Tests" on page 24.
80 Scheduled Maintenance	Printer has reached 200,000 prints (12C=100,000 prints) without maintenance count reset.
88 Toner Low	Toner sensor detects low toner.
90X Software Error	Unrecoverable software error. If one of these errors appeared during POST, or while the printer was idle (not printing or receiving data), or while trying to print one of the internal test pages, replace the system board. If the error appeared while sending a job from the host to the printer, turn the printer off, then turn it on and try again. If the error appears again, call the next level service support for assistance.
917 Transfer Roll Error	Cannot start servo operation. Verify correct cable connections from the Engine board to the HVPS. Make sure there is continuity between the transfer roller and its contact on the HVPS; replace the transfer roll if the continuity is correct. If there is no continuity, make sure the HVPS contact returns to its upward limit when depressed, and make sure the left bearing of the transfer roll is making proper contact.

Error/Code	Action
918 Transfer Roll Error	Servo Failure. Verify correct cable connections from the Engine board to the HVPS. Make sure there is continuity between the transfer roller and its contact on the HVPS; replace the transfer roll if the continuity is correct. If there is no continuity, make sure the HVPS contact returns to its upward limit when depressed, and make sure the left bearing of the transfer roll is making proper contact.
920 Fuser Error	Fuser is below temperature while printing. See "Fuser: 920, 921, or 922 Error" on page 20.
921 Fuser Error	Fuser is below standby temperature when idle. See "Fuser: 920, 921, or 922 Error" on page 20.
922 Fuser Error	Fuser failed to reach standby temperature. See "Fuser: 920, 921, or 922 Error" on page 20.
923 Fuser Error	Fuser is too hot while printing or when idle. See "Fuser: 923 Error" on page 21.
927 Fan Stalled	See "Fan (927 Error)" on page 19.
931 Printhead Error	No first hsync. See "Printhead" on page 28.
932 Printhead Error	Lost hsync. See "Printhead" on page 28.
934 Printhead Error	Lost lock condition. See "Printhead" on page 28.
935 Printhead Error	Mirror motor unable to reach operating speed. See "Printhead" on page 28.
941 System Board	ROM SIMM failed CRC; code data or font data. Run the diagnostic Memory Test for ROM. Replace the SIMM if the test fails or the problem recurs after POR; replace the system board if the SIMM does not fix the problem.
944 System Board	RIP processor failure. Replace the system board.
945 System Board	ASIC 1 failure. Replace the system board.

Error/Code	Action
946 System Board	ASIC 2 failure. Replace the system board.
947 System Board	Engine ASIC RAM failure. Replace the system board.
948 System Board	Engine ASIC electronics failure. Replace the system board.
950 System Board	SRAM failure. Replace the system board.
952 System Board	Unable to zero PQET SRAM. Replace the system board.
953 System Board	NVRAM failure. Replace the system board.
960 Memory Error	Bad or missing DRAM in the base DRAM slot. Reseat the DRAM and run the diagnostic Memory Test for DRAM. If test fails or the problem recurs after POR, replace the DRAM SIMM.
961 Memory Error	Bad DRAM in the optional DRAM slot. Reseat the DRAM and run the diagnostic Memory Test for DRAM. If test fails or the problem recurs after POR, replace the DRAM SIMM.
970 Network Card	Network card processor failure. Replace the Network Card.
971 Network Card	Network card RAM failure. Replace the Network Card.
972 Network Card	Network card ROS/FLASH failure. Replace the Network Card.
973 Network Card	Network card EEPROM/NVRAM failure. Replace the Network Card.
974 Network Card	Network card/Network interface error. Replace the Network Card.
976 Network Card	Network card software error. Verify that the network card is installed and grounded correctly. If this error returns after a POR, there is a software or microcode incompatibility problem. Do Not replace the card. Contact your next level of support.

Error/Code	Action
977 Network Card	Network card is installed but is not communicating with the system board. See "Network Card 977 Errors" on page 24.
978 Network Card	General network card hardware error. Replace the Network Card.
979 Network Card	General network card software error. Verify that the network card is installed and grounded correctly. If this error returns after a POR, there is a software or microcode incompatibility problem. Do Not replace the card. Contact your next level of support.
990 Duplex Option	Duplex error. See "Duplex" on page 18.
991 Duplex System Card Failure	Duplex system card failure. Replace the duplex system card.
993 Duplex Comm. Failure	Communications between the duplex unit and the printer have failed. See "Duplex" on page 18.

Power-On Self Test (POST)

When you turn the printer on, it performs a Power-On Self Test. Check for correct POST functioning by observing the following:

1. 1½ rows of pels appear on the display and then clear.
2. Diamonds fill the display and then clear.
3. The fuser lamp and the fan turn on. [Performing Self Test] appears on the display.

Note: The printer may be idle for up to 60 seconds as the fuser warms to operating temperature. Printer idle time is shorter if the fuser is already warm.

Note: If the duplexer is installed, the duplex drive motor turns on for about 5 seconds just before the ready screen appears.

4. The ready screen appears on the display.

Note: Diagnostics menu appears if you are in diagnostic mode.

5. The drive motor and the mirror motor start to run. The fan starts to run at high speed.
6. The drive motor runs for approximately 10 seconds. The fan runs at high speed, then switches to low speed.

If the printer completes all these steps and no error messages are displayed, the printer has successfully completed the POST.

Symptom Table

Symptom	Action or Service Check
Dead Machine	Dead Machine Service Check
Repeats pattern of five beeps and a pause.	Operator Panel Service Check
Machine Hangs Displaying Diamonds	Machine Hangs Displaying Diamonds Service Check
Operator Panel	Operator Panel Service Check
Paper Feed, Base Printer	Paper Feed, Base Printer Service Check
Paper Feed, Duplex Unit	Paper Feed, Duplex Unit Service Check
Paper Feed Problem, 500-sheet Second Tray	Paper Feed Problem, 500-sheet Second Tray Service Check
Paper Feed Problem, Envelope+ Feeder/100-Sheet Auxiliary Feeder	Paper Feed Problem, Envelope+ Feeder/100-Sheet Auxiliary Feeder Service Check
Automatic Paper Size Sensing Problem	Automatic Paper Size Sensing Problem Service Check
LAN Problems	LAN Service Check
Blank Page	Blank Page Service Check
Black Page	Black Page Service Check
Random Marks	Random Marks Service Check
Regularly Spaced Marks	Regularly Spaced Marks Service Check
Skew, all edges	Skew Service Check
Skew, top and bottom only	Skew, top and bottom Service Check
Light Print	Light Print Service Check
Fuzzy or Blurred Print	Fuzzy Blurred Print Service Check
Residual Image	Residual Service Check
Honeycomb	Honeycomb Service Check
Background	Background Service Check
Horizontal Void or Streak	Horizontal Service Check

Symptom	Action or Service Check
Vertical Void or Streak	Vertical Service Check
Banding	Banding Service Check

Banding

Banding appears as light and dark horizontal lines on a page that is supposed to be uniformly gray. It is due to variation in the speed of the paper as it moves from roll to roll during development or transfer. It is undetectable when printing text and is most noticeable on fine dot or horizontal line patterns such as the second page of Print Test 2 or Print Test 3. Inspect the gear train and the paperfeed rollers for wear, damage, dirt, or binds.

Background

Areas that are supposed to stay blank are getting small amounts of toner deposited on them. Clean the erase lamps and the printhead window.

Run the diagnostic Paper Feed Test and verify that all the erase lamps turn on. If not, verify that there is +24VDC on pin (10R/12R/12L/12C) J20-16 (16L) J17-16 (10P) J20-1 and between +15 and +20VDC on pin 15 (pin 2 on 10P). Shorting pin 15 (pin 2 on 10P) to ground should turn on all the erase lamps. Check the erase lamp cable continuity. Replace the transfer roll housing if the voltage and the cable are good.

Inspect the contacts on the HVPS; make sure each spring-loaded contact returns when pressed and released.

Rough Paper mode can cause background on some papers; if Rough Paper mode is on, turn it off and run the print test again. Printing on coated paper or using refilled print cartridges can also cause background.

Run the print test in continuous mode and check the following voltages; then stop the test and check the voltages again:

10R/12R/12C/ 12L	16L	Voltage while Printing	Voltage while Idling
J20-1 to J20-4	J17-1 to J17-4	Less than 1VDC	+21-26VDC
J20-2 to J20-4	J17-2 to J17-4	Greater than 1VDC	Less than 5VDC
J20-3 to J20-4	J17-3 to J17-4	The meter should fluctuate slightly between each page.	Less than 5VDC
J20-8 to J20-4	J17-8 to J17-4	Less than 1VDC	+21-26VDC

10P	Voltage while Printing	Voltage while Idling
J14-1 to J14-4	Less than 5VDC	0VDC
J14-2 to J14-4	Less than 5VDC	0VDC
J14-3 to J14-4	The meter should fluctuate slightly between each page.	0VDC
J14-8 to J14-4	1VDC	6VDC

If any voltages are not correct replace the system board.

Note: “Contrast” on the Diagnostics menu (changed to “Transfer” on 4039 plus machines) does not adjust the print contrast but changes the transfer algorithm slightly.

Users who run large jobs with very dense graphics in high humidity environments may get some print quality improvement from changing this setting; users with more normal jobs will see no difference.

Make sure the HVPS contacts to the transfer roll housing are in good condition.

Black Page

Black output is usually caused by an incorrect high voltage in the printing process, resulting in toner development on the entire photoconductor drum. Check the condition of each HVPS contact and make sure they spring back when pressed. Check the continuity of the HVPS cable. Make sure the following voltages are correct; if they are not, replace the system board.

10P	10R/12R/12C/ 12L	16L	Voltage
J14-5 to J14-4	J20-5 to J20-4	J17-5 to J17-4	+24VDC
J14-6 to J14-4	J20-6 to J20-4	J17-6 to J17-4	+24VDC

Make the following voltage checks while printing and again while idling. If the voltages are not correct, replace the system board.

10R/12R/12C/ 12L	16L	Voltage while Printing	Voltage while Idling
J20-1 to J20-4	J17-1 to J17-4	Less than 1VDC	21-26VDC
J20-2 to J20-4	J17-2 to J17-4	Greater than 1VDC	Less than 0.5VDC

10P	Voltage while Printing	Voltage while Idling
J14-1 to J14-4	Less than 5VDC	0VDC
J14-2 to J14-4	Less than 5VDC	0VDC

Blank Page

Inspect the printhead shutter for proper operation and make sure the actuator on top of the cartridge is present and extends into the printhead shroud when the printer top cover is closed. A failed printhead will cause a 931 Service error rather than blank output.

Check the continuity of the HVPS cable. The HVPS and transfer roll contacts should be clean and spring back when pressed. Make sure the transfer roll contact under the left bearing is making contact with the HVPS.

Make the following voltage checks while running the print test continuously and again while idling.

10R/12R/12C/ 12L	16L	Voltage while Printing	Voltage while Idling
J20-1 to J20-4	J17-1 to J17-4	Less than 1VDC	+21-26VDC
J20-2 to J20-4	J17-2 to J17-4	Greater than 1VDC	Less than 5VDC
J20-3 to J20-4	J17-3 to J17-4	The meter should fluctu- ate slightly between each page.	Less than 5VDC
J20-8 to J20-4	J17-8 to J17-4	Less than 1VDC	+21-26VDC

10P	Voltage while Printing	Voltage while Idling
J14-1 to J14-4	Less than 5VDC	0VDC
J14-2 to J14-4	Less than 5VDC	0VDC
J14-3 to J14-4	The meter should fluctuate slightly between each page.	0VDC
J14-8 to J14-4	1VDC	6VDC

If the voltages are not correct replace the system board.

Blurred or Fuzzy Print

This can be caused by a damaged gear train or by paper slippage in the feed roll or transfer roll. Also see “Banding” on page 13.

Inspect the HVPS contacts; make sure each spring-loaded contact returns when pressed and released. Inspect the transfer roll housing contacts for damage or contamination. Check the gear train for damage, binds, or wear.

When using the 100-sheet auxiliary feeder, some blurring may occur at the point where the feeder’s friction rollers release the paper.

Dead Machine

Possible causes: no voltage reaching the printer, LVPS failure, blown LVPS fuse, failure of the On/Off switch or switch linkage, or a shorted electrical component.

Check for the indicated voltages at the LVPS connection to the system board. If no voltages are present, remove the LVPS cover and check fuse F1 and the power switch before replacing the LVPS.

If some voltages are present, but all are not correct, disconnect all cables except the LVPS from the system board. POR and verify that the LVPS voltages are correct. Turn the power back off and, one at a time, reconnect the system board cables, powering on in between each connection and checking the voltages. The connection which causes the voltages to be wrong indicates which component is bad. Repair or replace the failing component or cable as necessary.

Duplex

The duplexer should home — the front shafts should turn and the input deflector should move — immediately when you install the duplexer with the printer already powered on, or when you POR the printer with the duplexer installed. This means the duplexer has completed its internal tests and is ready to communicate with the printer.

If the duplexer does not home it is either damaged or is not receiving +34VDC from the printer.

To check the connection from the printer system board to the duplex system board, remove the duplex top cover and table cover. Disconnect the duplex cable from the printer system board. From left to right (10P: top to bottom), the voltages on the printer system board connector pins should be 0, +34VDC, 0, +5VDC, 0, and +5VDC. With the cable connected, these voltages should also be at duplex system board JP4-1 through JP4-6. If you do not find a cable or voltage problem, replace the duplex system board.

A **933 error** indicates that communication between the printer and duplexer had been established but has been lost. Check the cable as above; if the error persists replace the duplex system board.

23 Paper Jams: Examine the paper path in the duplex unit and in the fuser exit area for paper or other obstructions. Make sure the duplex unit is positioned correctly on the printer, and that the gear at the bottom of the duplex unit meshes with the gear on the top of the paper tray. Check that the paper is fed with no skew or binds from the duplexer into the metal channel at the right edge of the tray cover. The tray roller should move the paper forward when the tray gear is turned, but allow the paper to be pulled by the D-roll when it picks. Make sure the belt to the duplex DC motor is in place. Make

sure the duplex table cover (floor) is correctly snapped in place at its front and rear and that the gear block assembly is correctly snapped into the bottom cover. Run duplex diagnostics tests #1 and #2 to make sure there is no slippage in the paper path. Make sure the flags of the duplex unit input and exit sensors move freely.

While the **23** is displayed, press and hold the Return button while pressing the second button from the top, and note the 7th and 8th digits from the left. If they are 01 or 03, there is a problem with the duplex input sensor signal. Remove the duplex top cover and table cover. Measure the voltage on JP6-3 of the duplex system board; it should fluctuate from 0 to +5VDC as you toggle the sensor flag. Check the sensor cable continuity. If the sensor and the cable are good, replace the duplex system card.

If the 7th and 8th digits are 04, there is an exit sensor problem. Remove the duplex top cover and table cover. Remove the paper tray so you can reach the sensor. Measure the voltage on JP6-8 of the duplex board; it should fluctuate from 0 to +5VDC as you toggle the sensor. Check the sensor cable continuity. If the sensor and the cable are good, replace the duplex system card.

Fan (927 Error)

The fan should run continuously when the printer is powered up, unless the printer is in Power Saver mode. Check that the fan rotates freely when spun manually and that the cable connections to the fan are OK. The voltage at (10P/10R/12R/12C/12L) J5-6 (16L) J3-6 should be approximately +24VDC when the top cover is up. Short pin 6 to ground to test the fan; if the fan does not run check the continuity of the fan cable before replacing the fan. A bad fan can pull down the +24V line even if it runs; check that (10P/10R/12R/12C/12L) J5-7 (16L) J3-7 has between +21 and +26VDC when the fan is running; if it does not, replace the system board.

Fuser Theory

The fuser lamp operates off line voltage from the LVPS. The thermistor is in contact with the fuser hot roll. The system board reads the thermistor resistance and toggles a TRIAC in the LVPS which cycles the lamp on and off to maintain the proper hot roll temperature. Inside the fuser shroud there is a thermal fuse which is in series with the lamp; if the TRIAC fails and leaves the lamp on continuously, the fuse melts and shuts off power to the lamp.

The thermistor output voltage is proportional to the fuser temperature and is on (10P/10R/12R/12C/12L) J19-6 (16L) J16-6. The voltage will cycle from approximately 2.0 to 2.3VDC as the lamp goes on and off during idle, and will be around 2.7VDC during continuous printing when the Fuser Temperature is set to Normal. In Power Saver mode the lamp is left off until a job is printed.

The system board signal to the LVPS TRIAC is on (10P)J11-16 (10R/12R/12C/12L) J11-3 (16L) J18-16. The voltage is 0VDC when the lamp is to be on and +24VDC (10P: +5VDC) when the lamp is to be off. The lamp can be tested by briefly connecting this pin to ground.

Fuser: 920, 921, or 922 Error

A 922 error during a POR caused by low line voltage can usually be cleared by doing another POR.

If the fuser lamp is lighting very dimly, check for a 220V lamp installed in a 110V machine.

Check all the connectors to the exit sensor card and the lamp power connections at the left end of the fuser. Make sure the thermistor is making contact with the hot roll. Check the continuity of the lamp, the thermal fuse, and the fuser power cable. Check the thermistor resistance at (10P/10R/12R/12C/12L) J19-5 to J19-6 (16L) J16-5 to J16-6; it should be from 100K Ohms to 260K Ohms when cold; it may be as low as 2.3K Ohms when hot but increases quickly as the fuser cools. There should be no connection from either pin to ground.

If the thermal fuse has blown, the fuser and the fuser wiper will be damaged. Before replacing the fuser and the fuser wiper, check the voltage at (10P) J11-16 (10R/12R/12C/12L) J11-3 (16L)J18-16 as you POR again. It should stay at 0 until the 922 Error is displayed and then go to +24VDC(10P: +5VDC); if it does not, replace the system board, the fuser, and the fuser wiper. Next, measure the voltage to the fuser lamp during a POR; it should be line voltage until the 922 Error is displayed, if it is not, replace the LVPS, the fuser, and the fuser wiper.

If the voltage to the fuser lamp is the not the same as the line voltage, replace the LVPS.

If the lamp, fuser power cable, thermal fuse, thermistor and lamp voltage are OK, check (10P)J11-16 (10R/12R/12C/12L)J11-3 (16L)J18-16 to see if the system board is sending the correct signal to the TRIAC. At POR this signal should go to +24VDC(10P +5VDC) and then immediately drop to 0VDC until the fuser is warm; if it does not, replace the system board. If the signal is OK, replace the LVPS.

Fuser: 923 Error

Check the connection and continuity of the cable from the fuser exit sensor board to system board (10P/10R/12R/12C/12L)J19 (16L)J16. Check the thermistor condition and connection.

Check the thermistor resistance at system board (10P/10R/12R/12C/12L)J19-5 to J19-6 (16L)J16-5 to J16-6. It should be from 100K Ohms to 260K Ohms when cold; it may be as low as 2.3K Ohms when hot but increase quickly as the fuser cools.

Honeycomb

(Areas of the page are covered with faint 6 mm circles.)

This print defect is usually caused by the print cartridge. If it is not the problem, verify that the tab on the transfer roll housing is touching the contact on the HVPS; the transfer roll housing should have continuity to ground. Make sure the HVPS ground lead to the side frame is in place and making good contact.

Horizontal Void or Streak

This is usually due to the cartridge not being installed correctly. Check the printhead area for obstructions, and check the mechanical workings of the print cartridge and printhead shutter. If nothing is found go to “Blank Page” and follow those instructions.

LAN Problems

You cannot find a printer or network problem, but jobs still do not print.

If the network card checks out successfully, the problem may be with the hardware or software outside of the network card. Below are some suggestions to the customer for checking hardware and software for possible problems. Refer the customer to the LaserPrinter Network Printer Utility Guide to find the problem.

- Make sure that the desired network protocol is enabled from the printer operator panel.
- Verify proper print queue and printer driver configuration
- Verify that the adapter port has been associated
- Verify correct installation of software utility
- Single route broadcast not supported across network bridge, if bridge is used
- Server problem; check print server installation and configuration using the appropriate system guide to operations.

Light Print

Light print is frequently caused by a worn out print cartridge. Clean the transfer roll by powering on and off two or three times, leaving the printer on for about two minutes each time. Other causes are the same as for "Blank Page".

Make sure Print Darkness on the customer menu is set to Normal or Dark. 10P: Increasing the diagnostics mode Print Contrast setting will darken print further.

PostScript emulation output may appear lighter than PCL output or a test print; this is not a defect. Verify on the Print Test that the print is too light before performing service.

Network Card 977 Errors

All network card errors are recorded as 977 in the error log. If there are 977 errors in the log, POR several times and take the appropriate action for the displayed error code.

If the displayed error is 977, verify that the network card is installed and grounded correctly. Remove the network card and check for +5VDC at pin B24 of (10P/10R/12R/12C/12L) J13 (16L) J12. If the voltage is incorrect replace the system board; if there is +5VDC replace the network card.

Network Wrap Tests

Token-Ring with Shielded Twisted-Pair Cable: Disconnect the LAN cable from the electrical outlet, leaving it connected to the printer network card.

Ethernet 10Base-2: Attach a 50 Ohm BNC terminator cap to each end of the T-connector. The customer may be able to provide this cap.

There is no wrap test for Token-Ring with Unshielded Twisted-Pair cable or for Ethernet 10Base-T.

POR the printer. If the printer completes POR successfully, the printer, network card, and the port to the LAN are working correctly. If the customer still has a problem printing, see "" on page 22.

Output Bin Sensor

Examine the bin area for obstructions or damage. Run the diagnostic sensor test.

For handle-mounted sensor: The voltage at sensor card J2-3 (pin 1 is the bottom pin) should be +5VDC, and the voltage at J2-4 should be (12L) 10 to 14VDC (16L) 22 to 26VDC. If these are incorrect and the cable has continuity, replace the system board. The voltage between J2-1 and J2-2 should be +5VDC when the light beam is not blocked, and near zero when it is blocked (the voltage takes 15 to 25 seconds to change to the low level).

For redrive-mounted sensor: make sure the plastic bails and guide are in good condition and that they guide the sensor flag out of and into the sensor as paper passes into the bin. On the sensor, the voltage from pin 2 to pin 3 (pin 1 is the bottom pin) should change from 0 to +5VDC as the sensor is blocked and unblocked. Pin 1 should always measure +5VDC.

Replace the sensor, the sensor card (on machines with latch-mounted sensor), or the sensor cable as necessary.

Operator Panel Problem

Possible causes: failed LCD or operator panel card, cable or connector problem, or system board problem.

Replace the operator panel if POR stops with 1½ rows of pels displayed.

Run the diagnostic tests for the LCD and for the buttons. If only some buttons or pels work, replace the operator panel.

If the operator panel is blank: check for +5VDC at pin 1 of the in-line connector under the top cover, and replace the operator panel if the voltage is good. Check for +5VDC at (10P/10R/12R/12C/12L) J7-1 (16L) J5-1 on the system board and replace the cable if the voltage is good.

If the voltage at the system board is incorrect, check that the LVPS is providing the correct voltages and replace the LVPS if its output voltages are wrong.

On models 10R/12R/12C/12L, a DC-DC convertor changes +34VDC at J9-1 into +5VDC, +12VDC, and -12VDC. Check for +5VDC at J8-1 and for +34VDC at J9-1 and at J11-4. Replace the DC-DC convertor, the system board, or the LVPS depending on where the voltage is incorrect.

Paper Feed Problem, 500-Sheet Second Tray

Remove the module and inspect the tray, the module D-roll bias spring, the gear train, and the paper feed magnet spring. Make sure the gear train is meshing with the drive gear at the bottom of the printer. Look for other mechanical problems or damage. Make sure the cable connector is in good condition. The resistance of the paper feed magnet should be 100 Ohms to 250 Ohms. If paper is not feeding correctly check the magnet adjustment.

Paper Feed, Base Printer

Run the print test or the diagnostic paper feed test and carefully examine the area of the problem.

If paper is not feeding, make sure the paper is in the tray correctly and is not damaged or stuck together. Make sure the D-roll is in good condition and rotates when the magnet is picked. With the 500-sheet trays, make sure the tension wheel is set high enough to give good contact between the D-roll and the paper stack.

10R/12R/12C/12L/16L: Make sure the pick magnet is being energized. The pick magnet should have a resistance of 100 to 250 Ohms. The voltage at (10R/12R/12C/12L) J22-2 (16L) J19-2 should be +34V between picks, and drop to about +30VDC (it actually drops to zero but most meters will not react quickly enough) briefly during the pick; listen for the noise of the solenoid at the same time the voltage changes. The magnet can be tested by shorting pin 2 to ground and listening for it to pick.

10P: The 10P has a torquer motor to activate the D-roll. It is connected at J22 of the system board, the voltage check is the same as the 10R/12R/12C/12L/16L. The resistance of the motor is 88 Ohms. The motor can be tested by shorting pin 2 to ground and listening for it to pick.

If paper feeds but stops undamaged in the paper path there may be a sensor problem. Run the diagnostic test for the input and exit sensors replace as necessary. Check the continuity of the cable before replacing the sensor. The input sensor signal is on (10P)

J20-6 (10R/12R/12C/12L) J20-11 (16L) J17-11; the output sensor signal is on (10P/10R/12R/12C/12L) J19-8 (16L) J16-8. The voltage should be 0VDC when there is no paper in the sensor and +5VDC when paper is present.

If paper is jamming, clean the paper path of obstructions or repair any damaged parts. Very thin or thick paper, labels, transparencies, or card stock will have a higher jam rate than regular xerographic paper. Check the condition of the paper in the tray and verify that the tray is installed correctly.

If paper is curling badly enough to cause a problem feeding or stacking, see “Fuser Temperature And Warm-Up Time” on page 40.

Paper Feed, Duplex Unit

Check that all gears and belts are working correctly both in the duplex unit and on the tray top cover, and that the gear on the tray top cover engages the gear on the duplexer.

If paper is jamming in the table cover area, make sure the table cover is properly installed. Run diagnostics Duplex Test 1 to make sure the paper is feeding far enough into the duplex unit before reversing. Examine the condition of all rollers.

If paper is stopping or jamming as it is fed back across the top of the paper tray, run diagnostics Duplex Test 2 to make sure there is no slippage in the paper path. Make sure the paper tray top cover is not damaged. Cold paper curl can also cause jams here; see “Fuser Temperature And Warm-Up Time” on page 40.

If paper is jamming at the front exit, verify that the front exit deflector switch is functioning by disconnecting (10P/10R/12R/12C/12L) J19 (16L) J16 and checking the resistance from pin 1 to pin 2 as you operate the switch.

Also see “23 Paper Jams” on page 18

Paper Feed Problem, Envelope+ Feeder/ 100-Sheet Auxiliary Feeder

Check for the following: paper or envelope jammed in the feed path; missing hold-down weight; adjustable guide out of position; feeder cable loose, disconnected, or plugged in the wrong connector; feeder incorrectly installed; worn or damaged rollers or gears; warped or damaged envelopes being used; envelopes being improperly installed (envelope flaps must rest against the paper edge guide); envelopes other than 20- or 24-pound being used in the envelope+ feeder; paper other than 20- or 24-pound being used in the 100-sheet auxiliary feeder; envelopes being interleaved with paper.

Run the diagnostics Envelope Feed test and make sure the feed magnet is being energized. If not, check the resistance of the magnet at (10P/10R/12R/12L/12C) J12-1 to J12-2 (16L) J9-1 to J9-2 on the feeder cable; the resistance should be from 105 Ohms to 155 Ohms. If the magnet is good, reconnect the cable and monitor the voltage between the two pins of the connector while running the Envelope Feed test; if the voltage does not increase momentarily as the magnet is picked, replace the system board.

Check the adjustment of the feeder magnet. If paper is being bent or double-fed, check the adjustment of the feeder restraint spring.

Printhead

Note: The printhead is a sealed unit. It contains no parts that can be replaced or serviced.

Verify the continuity of the fan/mirror motor cable and the hsync cable. Verify the presence of the following voltages: +24VDC at (10P/10R/12R/12C/12L) J5-1 (16L) J3-1, +5VDC at (10P/10R/12R/12C/12L) J6-5 (16L) J4-5, +5VDC at (10P/10R/12R/12C/12L), J6-1 (16L) J4-1.

If these voltages are not correct, replace the system board.

Verify +5VDC at pin 5 on the fan/mirror motor cable at the mirror motor board. If the voltage is correct replace the printhead; if the voltage is bad and the cable is OK replace the system board.

Paper Size Sensing Problem

(The printed area does not fit on the page, or the paper size cannot be changed from the operator panel.)

Make sure that paper trays for the 4019, 4028, or 4029 are not being used in the 4039 printer.

Make sure the paper tray and its stops are undamaged. Make sure the cable to the paper size switch is connected correctly.

Disconnect (10P/10R/12R/12C/12L) J19 (16L) J16 from the system board before making the following measurements. With the tray removed, make sure there is no continuity from (10P/10R/12R/12L/12C) J19-3 to J19-4 (16L) J16-3 to J16-4 on the cable; replace the paper size switch if the resistance is not infinite.

The resistance from (10P/10R/12R/12L/12C) J19-3 to J19-4 (16L) J16-1 to J16-2 varies with the paper size. With the tray installed, if the readings do not match the following within 5% replace the paper size sensor.

A5	1.4 K Ohms (tray 1 only)
B5	2.0 K Ohms
10.5"	3.0 K Ohms
11"	4.7 K Ohms
A4	8.0 K Ohms
13" or 14"	17.8 K Ohms (legal tray)

If the problem is with the 500-sheet option, the resistance from (10P/10R/12R/12L/12C) J17-3 to J17-4 (16L) J14-3 to J14-4 should be infinite with no tray installed, or with the tray installed, should match the table.

Regularly Spaced Marks

This is caused by a defect on one of the rolls or gears in the print process. The damaged part can be determined by the spacing of the marks according to the following table. Find and replace the damaged part.

Component	Print Defect Spacing on Page
PC Drum (part of print cartridge)	125.7 mm
Transfer Roll	53.1 mm
Fuser Hot Roll10P/12R/12C/12L/16L	78.9-79.2 mm
Fuser Hot Roll 10R	64.7 mm
Fuser Backup Roll	69.1 mm
Charge Roll (part of print cartridge)	37.1-37.7 mm
Developer Roll (part of print cartridge)	40.0 mm
Prealigner Feed Roller	68.5 mm
Auxiliary Feed Roller	68.5 mm

Spacings other than the ones listed could be caused by damage or a bind in the gear train.

Residual Image

Residual image--the "walking" of a leftover image down the page--is probably the result of failed erase lamps not discharging the photoconductor, or of a failed cleaner inside the print cartridge. It can also be caused by a failed fuser hot roll retaining toner and redepositing it on the page. Check that the erase lamp voltage at (10P) J20-1 (10R/12R/12C/12L) J20-16 (16L) J17-16 is +24VDC and that the cable has continuity.

To test the erase lamps, jumper (10P) J20-2 (10R/12R/12C/12L) J20-15 (16L) J17-15 to ground.

Random Marks

Random marks are nearly always due to a mechanical problem or due to foreign matter loose in the printer or in the print cartridge. Inspect and clean the inside of the printer carefully and correct any problems found.

Skew, all edges

If the test print frame is parallel to all edges of the page but the margins are not all the same width see “Print Registration Adjustment” on page 63.

If the test print frame is not parallel to the left and right edges of the paper, the paper has skewed in the paper path. Check the paper path for obstructions. Make sure the paper in the tray is loaded properly and is undamaged. Check the prealigner, drive, and auxiliary rollers, springs, and backup rollers for dirt, wear, or damage; refer to the parts catalog for repair kits for broken bellcrank spring attachment hooks on the sideframe. Make sure all the bellcrank assemblies pivot freely. Check the gear train for damage or binds.

Skew, top and bottom only

If the test print frame is parallel to the left and right edges of the paper but not parallel to the top and bottom, the printhead skew needs to be adjusted. See “Printhead Skew - Level 1” on page 61 and “Printhead Skew - Level 2” on page 62.

Stalled (diamonds on display)

Check the continuity of the cable from (10P/10R/12R/12C/12L) J7 (16L) J5 on the system board to the operator panel. Next, reseal the ROM and memory SIMMs and POR. This condition can also occur on models 10R/12R/12L/12C if a network card is installed without the accompanying DC power card.

If the problem is still present, replace one at a time the:

1. ROM SIMM
2. System board

Vertical Void or Streak

Do a developed image test to determine if the defect is occurring before or after the transfer process.

If you see the defect on the photoconductor, check the operation of the printhead shutter and clean the printhead window with a lint-free cloth folded over a cotton swab; do not use a bare swab and do not use any cleaning fluids or water on the printhead window. Inspect the HVPS contacts.

If the image on the photoconductor is good, inspect the fuser rolls and transfer roll. Make sure the left transfer roll bearing is contacting the contact from the HVPS. Make sure the HVPS contacts are clean and spring back when pressed.

Diagnostic Aids

Diagnostics Mode

To run some of the printer diagnostic tests described in this chapter, you must put the printer in Diagnostics mode.

To enter Diagnostics mode:

1. Turn the printer off.
2. Press and hold the Ready and Return buttons. Then turn the printer on. The printer performs the Power-On Self Test.
3. Release the buttons when [Performing Self Test] is displayed.
4. You can exit Diagnostics mode without a POR by selecting [Reset Printer].

Grouped Diagnostic Aids

Print Tests

Print Test Page
Developed Image Test
Print Tests

Registration Tests

Print Registration
Quick Test

Paper Feed Tests

Envelope Print Test
Paper Feed Test

Printer Setup Tests

Envelope Enhance
Print Contrast (Transfer)
Fuser Temperature/Warm-up Time

Hardware

Defaults
Memory Tests
Sensor Test
Auto Clean
Auto Clean Frequency
Auto Clean Delay
Error Log

Operator Panel Tests

Button Test
LCD Test

Duplex Tests

Duplex Feed 1
Duplex Feed 2

Page Counts

Page Count
Maintenance Kit Count
Permanent Page Count

Device Tests

Quick Disk Test
Disk Test/Clean

Connection Checks

LAN Information
Wrap Tests
Serial Interface Option

Alphabetical List of Diagnostic Aids

Auto Clean

Auto Clean needs to be turned on if there is an unacceptable amount of toner being deposited on the back of the page. When Auto Clean is on, after printing the number of pages specified in Auto Clean Frequency, the printer pauses the number of seconds specified in Auto Clean Delay. This pause minimizes the toner accumulating on the fuser cleaner.

1. Enter Diagnostics mode.
2. Select [Auto Clean].
3. Select [On] or [Off].
4. Press Return to return to Diagnostics mode main menu.

Auto Clean Delay

This can be set from 1 to 60 seconds with a default of 1. Auto Clean Delay does not appear on the menu unless Auto Clean is on.

1. Enter Diagnostics mode.
2. Select [Auto Clean Delay].
3. Select [+] or [-] to display the delay desired.
4. Select [SAVE].
5. Press Return to return to Diagnostics mode main menu.

Auto Clean Frequency

This can be set from 10 to 255 pages with a default of 50. Auto Clean Delay does not appear on the menu unless Auto Clean is on.

1. Enter Diagnostics mode.
2. Select [Auto Clean Frequency].
3. Select [+] or [-] to display the frequency desired.
4. Select [SAVE].
5. Press Return to return to Diagnostics mode main menu.

Defaults

Allows setting the following defaults to U.S. or Non U.S. values.

U.S.	NON U.S.
Letter size paper	A4 paper
# 10 envelopes	DL envelopes
Symbol Set Roman-8	Symbol Set PC-850

1. Enter Diagnostics mode.
2. Select [Defaults].
3. Select [U.S.] or [Non U.S.].
4. Press Return to return to Diagnostics mode main menu.

Developed Image Test

Use the Developed Image Test to isolate print quality problems. You might have to practice this procedure several times to get the timing correct.

To run the Developed Image Test:

1. Set the paper exit lever to use the front exit.
2. Print the test page.
3. As soon as the leading edge of the paper is visible coming out the front exit slot, turn off the printer.
4. Remove the print cartridge and look at the image on the photoconductor.

Disk Test/Clean

This is a two hour test that should be performed only on a disk that contains bad data and is therefore unusable.

This test destroys all data on the disk by doing a multi-pass write/read on every block of the disk. Bad blocks are flagged and removed from use. If over 2000 bad blocks are found the test stops and the display indicates the disk must be replaced.

A message describing test progress is displayed during the test.

1. Enter Diagnostics mode.
2. Select [Device Test]
3. Select [Disk Test/Clean].
4. Select [CONTINUE] to start the test, or [CANCEL] to return to Diagnostics mode main menu.
5. Select [CANCEL] to interrupt the test.
6. Press Return to return to Diagnostics mode main menu.

Duplex Feed 1 Test

This test checks for slipping paper problems. It verifies that the paper is entering the duplex unit far enough for the trailing edge to clear the selector fingers before the paper reverses direction.

1. Enter Diagnostics mode.
2. Select [Duplex Tests].
3. Select [Duplex Feed 1].
4. Select [Tray 1], or [Tray 2].

Note: Paper feeds all the way into the duplex unit and stop.

5. The message [CLEAR PAPER] appears on the display.
6. Slide the tray extension all the way out until it stops.
7. Push a small screwdriver through the lower end of one of the ventilation slots and through the sheet of paper fed in under the slot.
8. Open the cover and remove the sheet of paper.
9. Measure the distance from the mark on the paper to the trailing edge of the paper. If the mark, or hole, is more than 95 mm from the trailing edge, there is a paper slipping problem with the duplex unit paper feed.

Duplex Feed 2 Test

This test verifies that paper feeds through the duplex unit properly and tests the stop point of the page as it feeds back over the top of the duplex paper tray.

1. Enter Diagnostics mode.
2. Select [Duplex Tests].
3. Select [Duplex Feed 2].
4. Select [Tray 1] or [Tray 2].

Note: Paper feeds all the way into the duplex unit and then feed out and stop on top of the paper tray.

5. The message [CLEAR PAPER] appears on the display.
6. Open the printer top cover.
7. If you are doing the test with legal size paper, open the top cover of the duplex unit.
8. Carefully remove the duplex unit from the printer without disturbing the position of the paper on the top of the duplex tray. Do not disconnect the duplex cable from the printer.
9. Without changing the position of the page, hold it to the top of the paper tray and remove the paper tray.
10. Measure from the leading edge of the page to the leading edge of the paper stack in the tray. This measurement should be 75 mm or less. If it is larger than 75 mm, there is a drive problem in the duplex unit or in the tray top cover.
11. Select [CONTINUE].
12. Perform the test several times to verify that the measurement is accurate.
13. Press Return to return to Diagnostics mode main menu.

Envelope Enhance

Use this procedure to set the fuser solenoid power level to low, medium, or high. Increase the level to reduce envelope wrinkling, or decrease the level to reduce solenoid noise.

1. Enter Diagnostics mode.
2. Select [Envelope Enhance].
3. Select [Low], [Medium], or [High].
4. Press Return to return to Diagnostics mode main menu.

Envelope Print Test

Note: Printing only occurs on the first envelope. The envelope feeds from the automatic envelope feeder if present. If there is no automatic feeder present, the printer uses manual envelope.

1. Enter Diagnostics mode.
2. Select [Envelope Print].
3. Select [Single] or [Continuous].
4. Select [CANCEL] to stop continuous envelope feed.
5. Press Return to return to the Diagnostics mode main menu.

Error Log (“plus” machines only)

The error log records the last 6 “2X Paper Jam” or “9XX Service” errors. In a full log, position 6 is the oldest error. If more than 6 errors are received, the oldest error is discarded. If the same error occurs consecutively it is recorded only once.

All 97X Network Card errors are logged as 977.

1. Enter Diagnostics mode.
2. Select [Error Log].
3. Select [CLEAR] and then [CONTINUE] to clear the error log.
4. Press Return to return to Diagnostics mode main menu.

Fuser Temperature And Warm-Up Time

These settings allow adjustment of the fuser to correct problems with paper curl or melting letterheads.

Paper curl in which the top and bottom of the page curl toward the printed side (hot paper curl) can be corrected by reducing the fuser temperature. Reduce the setting from Normal to No Boost; if necessary, reduce the setting further to Low Temperature. Verify that the toner is being adequately fused to the paper at the new temperature setting.

Paper curl in which the edges of the paper curl toward the printed side (cold paper curl) can be corrected by increasing the fuser warm-up time. Use the lowest setting that corrects the problem. Setting "0" is the factory default and is the shortest warm-up time. Setting "5" increases warm-up time by 90 seconds; lower settings increase the time proportionately less. Settings other than "0" may reduce throughput. Use the + or - key to change the number and then select save.

Melting letterheads may be prevented by reducing the fuser temperature as described above for paper curl.

Fuser Temperature

1. Enter Diagnostics mode.
2. Select [Fuser Temperature].
3. Select [Normal], [No Boost], Or [Low Temperature].
4. Press Return to return to the Diagnostics mode main menu.

Warm-up Time

1. Enter Diagnostics mode.
2. Select [Warm-Up Time].
3. Select a setting of "0" through "5". Use the + or - key to change the number. 0 is the shortest fuser warm-up (factory setting). 5 is the longest fuser warm-up.
4. Press Return to return to the Diagnostics main menu.

Maintenance Kit Count

This non-displayed counter must be reset after the maintenance kit is replaced to prevent the [80 Scheduled Maintenance] message from displaying when the machine is turned on.

1. Enter Diagnostics mode.
2. Select [Maintenance Count].
3. Select [RESET] to set the count back to "0".
4. Press Return to return to the Diagnostics mode main menu.

Memory Test

1. Enter Diagnostics mode.
2. Select [Memory Test].
3. Select either [DRAM] or [ROM].
4. Select [Single] or [Continuous].
5. The display indicates [PASSED], or [FAILED].
6. Select [CANCEL] to stop continuous memory test.
7. Press Return to return to Diagnostics mode.

Operator Panel Tests

The following tests check for proper functioning of the operator panel buttons and display (LCD).

Button Test

To test the operator panel buttons:

1. Enter Diagnostics mode.
2. Select [Button Test].
3. Press each button. [Closed] is displayed until the button is released. Then [Open] is displayed.
4. Press Return to return to the Diagnostics mode main menu.

LCD Test

To test the operator panel display:

1. Enter Diagnostics mode
2. Select [LCD Test].
3. Select [Single] or [Continuous].
4. The display goes through a continuous sequence of turning pels on and off.
5. Press Return to stop continuous LCD test.
6. Press Return to return to the Diagnostics mode main menu.

Page Count

To view or set the page count:

1. Enter Diagnostics mode.
2. Select [Page Count].
3. Choose any number between 0000000 and 9999999 by Selecting [NEXT] to move the cursor under each digit. Then select [+] OR [-] to select the number you want in each digit.
4. Select [SAVE] to save the page count displayed.

Paper Feed Test

This test allows you to observe the drive gear train and feed paper through the printer to check for broken gear teeth, watch the paper path, or check the erase lamps.

Note: You may want to remove the gear cover before starting this test so you can observe the motor gears.

1. Enter Diagnostics mode.
2. Select [Paper Feed].
3. Select [Tray 1], [Tray 2], or [Manual].
4. Select [Single] or [Continuous].
5. Select [CANCEL] to stop continuous mode.
6. Press Return to return to Diagnostics mode main menu.

Permanent Page Count

The permanent page count can be displayed only. It cannot be modified or reset by the customer or servicer.

1. Enter Diagnostics mode.
2. Select [Permanent Page Count].
3. Press Return to return to Diagnostics mode main menu.

Print Contrast (Transfer on “plus” machines)

This setting changes the transfer roll voltage to light, medium, or dark (low, medium, or high on “plus” machines), but seldom produces a visible difference in print darkness. This setting may be useful in environmental extremes to prevent toner from being deposited in white areas next to large black areas.

1. Enter Diagnostics mode.
2. Select [Print Contrast].
3. Select [Light], [Medium] or [Dark]; ([Low], [Medium] or [High] on plus machines).
4. Press Return to return to the Diagnostics mode main menu.

Print Registration

See “Print Registration Adjustment” on page 63.

Print Test Page

You can run the Print Test even if the printer is not attached to a computer. Use this test to check print and graphics quality and the version numbers of printer microcode. The first page of this test feeds from tray 1. Following pages continue to feed from this tray unless you change the paper source.

To run the Print Test:

1. Turn the printer on.
2. Select [MENU].
3. Select [TESTS MENU].

4. Select [Print Test Page].
5. Select either [Single] or [Continuous] depending if you want one page or continuous test pages.
6. Select [Stop] when you want the continuous test to end.

Print Tests

All of the print tests can be run in the [Single] or [Continuous] mode. To stop continuous printing select [CANCEL].

Print Test 1

Print Test 1 generates one print out similar to the test page. This test uses paper from tray 1 only. Print Test 1 will not duplex.

To run Print Test 1:

1. Enter Diagnostics mode.
2. Select [Print Test 1].
3. Select [Single] or [Continuous].
4. Select [CANCEL] to stop continuous print.
5. Press Return to return to the main Diagnostics menu.

Print Test 2

Print Test 2 generates two printouts: a page similar to the test page, and a fine dot pattern which can be used to evaluate banding or other print quality problems.

Print Test 2 duplexes if the duplex option is installed.

To run Print Test 2:

1. Enter Diagnostics mode.
2. Select [Print Test 2].
3. Select [Single] or [Continuous].
4. Select [Cancel] to stop continuous print.
5. Press Return to return to the main Diagnostics menu.

Print Test 3

This test generates 2 printouts: a solid black page, and a dot pattern that can be used to evaluate print quality.

1. Enter Diagnostics mode.
2. Select [Print Test 3].
3. Select [Single] or [Continuous].
4. Select [CANCEL] to stop continuous print.
5. Press Return to return to Diagnostics mode main menu.

Quick Disk Test

This is a one minute test which performs a non-destructive write/read on one block per track on the disk. It tests the printer-to-disk communications, and the disk hardware and circuitry but does only incidental testing of the disk surface itself.

The Quick Disk Test does not destroy data on the disk; existing data is read and stored prior to the testing of each track, and then re-written after the track is tested.

1. Enter Diagnostics mode.
2. Select [Quick Disk Test].
3. The display indicates [Test Passed] or [Test Failed].
4. Press Return to return to Diagnostics mode main menu.

Quick Test

The Quick Test is activated by pressing Ready from any screen while in Diagnostics mode (“plus” machines only), as well as being an entry under [Print Registration]. It provides a simple page alignment pattern that prints faster than the other print tests.

Sensor Test

1. Enter Diagnostics mode.
2. Select [Sensor Test].
3. Select one of the following sensor tests.
 - Toner Low
 - Output Bin
 - Input
 - Exit
 - Cover Open

Note: The Output Bin sensor can have up to a 15 second delay in changing to open.

4. When the sensor is blocked [Open] is displayed. Otherwise, [Closed] is displayed.
5. Press Return to return to the Diagnostics mode main menu.

Network Connections and Checks

Wrap Tests

The Wrap Tests check the circuits used to communicate with the host computer.

To run the Wrap Test:

1. Turn the printer off.
2. Disconnect the interface cable.
3. Install the wrap plug in one of the interface cable connectors.

Note: Install the parallel wrap plug part no. 1319128 for the parallel test or install the 25 pin serial wrap plug part no. 1329048 for the serial test.

4. Enter Diagnostics mode.
5. Select [Wrap Test].
6. Select [Parallel] for the parallel port or [Serial] for the 25 pin serial port.
7. Select [Single] or [Continuous].
8. Select [CANCEL] to stop continuous.

A [PASSED] message indicates the printer connection to the printer cable connector is good.

A [FAILED] message indicates a defective system board.

Note: Ignore the number displayed after a failure is displayed.

9. Press Return to return to the Diagnostics mode main menu.
10. Turn the printer off, then remove the wrap plug from the interface connector.

LAN Information

The printer may be connected to one of the following LAN types:

Token-Ring

Ethernet 10BaseT

Ethernet 10Base2

LocalTalk**

The Network external connectors are pictured below. The printer test page also indicates to which type of LAN the printer is connected.

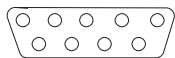

Token Ring

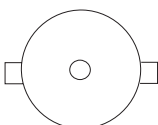

Ethernet 10Base2

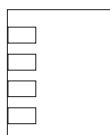

Ethernet 10BaseT

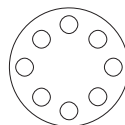

LocalTalk

Serial Interface Option, 10P

The serial interface unit switch settings determine how the printer receives data from the computer or terminal. Set the switches according to your particular equipment requirements.

The serial interface has 12 function switches.

Function Switch Setting

Switches 1 to 4 — Speed: Switches 1 through 4 define the serial interface speed in bits per second (bps).

1	2	3	4	SPEED (BPS)
On	On	Off	Off	150
On	Off	On	Off	300
On	Off	Off	Off	600

1	2	3	4	SPEED (BPS)
Off	On	On	Off	1,200
Off	On	Off	Off	2,400
Off	Off	On	Off	4,800
Off	Off	Off	Off	9,600 (default)
On	On	On	Off	19,200
Off	Off	Off	On	38,400 (RS-422 only)

Switch 5 – Data Bits: Switch 5 selects the number of data bits (7 or 8) in each data frame.

5	DATA BITS
Off	8
On	7

Switch 6 and 7 – Parity: Switches 6 and 7 select the interface parity.

6	7	Parity
Off	Off	No
Off	On	Ignore
On	Off	Odd
On	On	Even

Note: When setting the “Ignore” for parity, the printer ignores the received parity and transmits using Even parity. For all other parity settings, the transmitted parity matches the received parity.

Switch 8 – Buffer Size: Switch 8 allows the adapter buffer size to be limited, to minimize the amount of data in the buffer at any time.

8	Buffer Size
Off	Normal
On	Minimum

Switch 9 – Protocol: Switch 9 selects the type of protocol.

9	Protocol
Off	DTR pacing (RS232 only)
On	XON/XOFF

Switch 10 - Print Test: Switch 10 selects the print test for the serial interface card. This tests the connection between the serial interface unit and the printer. The printout contains the serial interface unit code level and switch settings, and the printer character set.

Note: For the serial print test to work [Advanced Status] (found under the [PARALLEL SETUP] menu) must be set to [Off].

To run the serial interface test print:

1. Turn the printer power off.
2. Set serial interface Switch 10 [On].
3. Turn the printer power on.

If the printer does not generate a printout, there is a problem with the serial interface card or its connection to the printer. Check the switch settings and ensure that the serial interface unit is correctly installed.

When the test is complete, reset Switch 10 to [Off].

10	Print Test
Off	Normal Mode
On	Test mode

Switch 11 – Polarity for RS-422 Serial Interface: Switch 11 is used to reverse the polarity of the receive and transmit data line for the RS-422 serial interface.

11	Mode
Off	Normal
On	Reverse

Switch 12 – Interface: Switch 12 sets the serial interface in either RS-232C or RS-422 mode.

12	Mode
Off	RS-232C
On	RS-422

Repair Information

This chapter explains how to make adjustments to the printer and how to remove defective FRUs.

Handling ESD-sensitive Parts

Many electronic products use parts that are known to be sensitive to electrostatic discharge (ESD). To prevent damage to ESD-sensitive parts, follow the instructions below in addition to all the usual precautions, such as turning off power before removing logic boards:

- Keep the ESD-sensitive part in its original shipping container (a special “ESD bag”) until you are ready to install the part into the machine.
- Make the least-possible movements with your body to prevent an increase of static electricity from clothing fibers, carpets, and furniture.
- Put the ESD wrist strap on your wrist. Connect the wrist band to the system ground point. This discharges any static electricity in your body to the machine.
- Hold the ESD-sensitive part by its edge connector shroud (cover); do not touch its pins. If you are removing a pluggable module, use the correct tool.
- Do not place the ESD-sensitive part on the machine cover or on a metal table; if you need to put down the ESD-sensitive part for any reason, first put it into its special bag.
- Machine covers and metal tables are electrical grounds. They increase the risk of damage because they make a discharge path from your body through the ESD-sensitive part. (Large metal objects can be discharge paths without being grounded.)
- Prevent ESD-sensitive parts from being accidentally touched by other personnel. Install machine covers when you are not working on the machine, and do not put unprotected ESD-sensitive parts on a table.
- If possible, keep all ESD-sensitive parts in a grounded metal cabinet (case).
- Be extra careful in working with ESD-sensitive parts when cold-weather heating is used because low humidity increases static electricity.

Adjustments

Envelope Restraint Spring On The Envelope+ Feeder

1. Loosen the mounting screw [A].
2. Position the spring [B] so it clears the separator roller by 1.9 ± 0.2 mm (0.075 ± 0.008 in.).
3. Tighten the mounting screw.

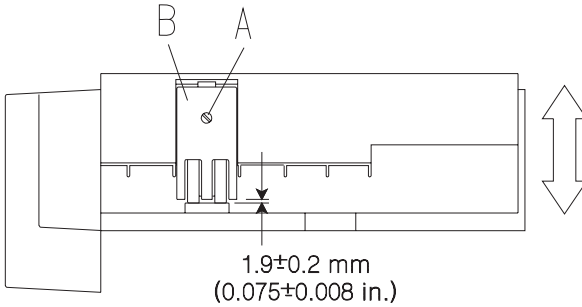

(Rear View)

Paper Restraint Spring On The 100-sheet Auxiliary Feeder

1. Loosen the mounting screw [A].
2. Position the spring [B] so it clears the separator roller by 1.9 ± 0.2 mm (0.040 ± 0.008 in.).
3. Tighten the mounting screw.

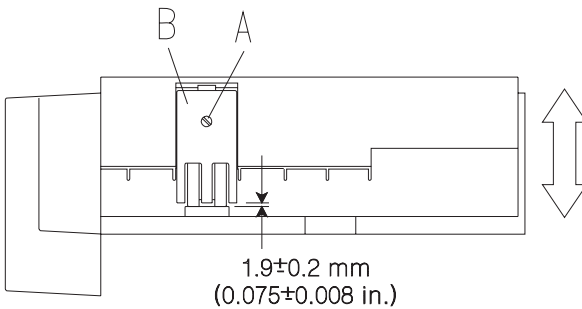

(Rear View)

Envelope Feeder Magnet And 100-sheet Auxiliary Feeder Magnet

1. Hold the armature [A] in the closed (coil active) position.
2. Loosen the mounting screw [B], and rotate the magnet assembly so the armature clears the clutch gear by 0.30 ± 0.20 mm (0.012 ± 0.008 in.).
3. Tighten the screw.
4. Check the adjustment on both sides of the gear.

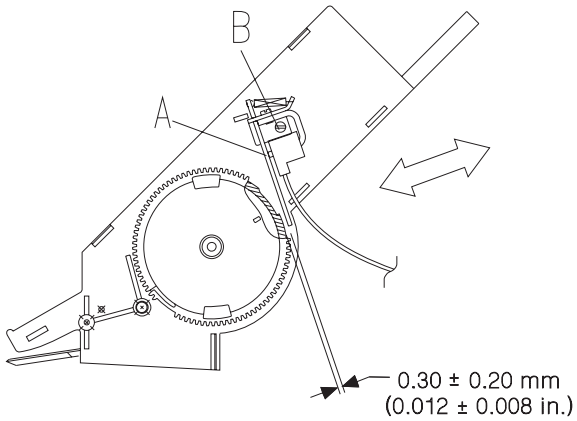

Fuser Drive Gear Backlash

Fuser drive gear backlash is adjusted so that when gear #2 is held still, there is a slight amount of backlash in the fuser gear. Print quality can be affected if the gears are too tight.

1. Remove the fuser cover.
2. Locate gear #2. It is the white adjustable gear mounted to the side frame below the fuser gear.
3. Rotate the adjustable gear in one direction to check for backlash.

To adjust backlash:

1. Loosen the nut on the idler stud.
2. Move the idler stud downward in its slot.
3. Insert a 0.95 mm (.037) feeler gage between the gear shoulders from the front of the machine. You may need to use an angled or very small feeler gauge.
4. With the nut snug but not tight, tap the idler upward until the gage is snug between the gear shoulders.
5. Tighten the locking nut.
6. Check the clearance again; tightening may have altered the adjustment. Be sure the fuser gear can be rotated slightly when gear #2 is held still.

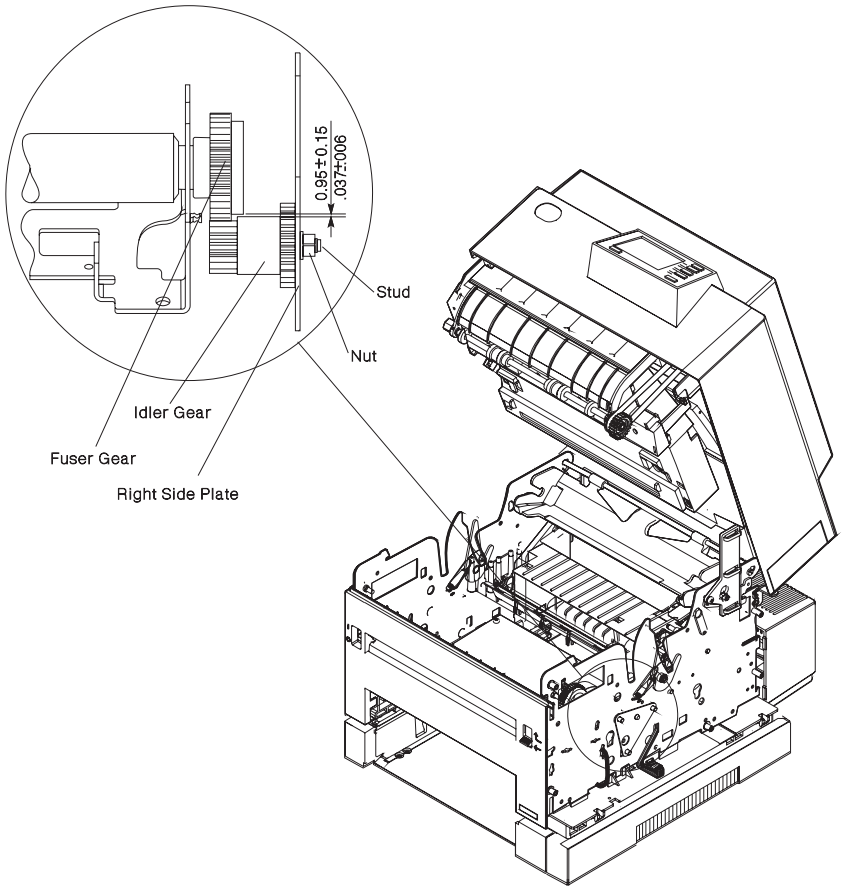

Fuser Solenoid

Note: The fuser solenoid must be mounted on the fuser for this adjustment and should be at room temperature.

1. Loosen screw [A].
2. Remove the rubber washer.
3. Rotate shaft [B] (eccentric) to obtain $4.2 \text{ mm} \pm 0.2 \text{ mm}$ ($0.165 \text{ in.} \pm 0.008 \text{ in.}$) air gap.
4. Tighten screw [A].
5. Replace the rubber washer.

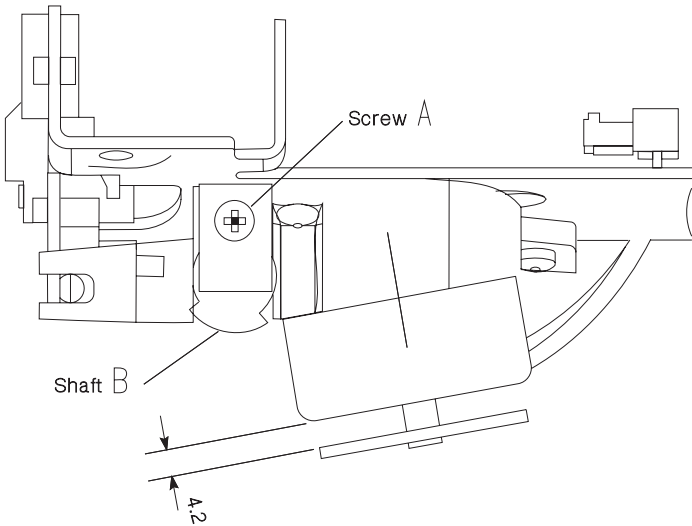

Paper Feed Magnet

1. Remove the system board. The magnet is accessed through the holes in the right frame.
2. With the armature latched on the cam step check for $0.60 \text{ mm} \pm 0.07 \text{ mm}$ ($0.024 \text{ in.} \pm 0.003 \text{ in.}$) between the foam pad and the magnet pole piece. If adjustment is required, continue:
3. Keep the armature latched and loosen the magnet mounting screw [A].
4. Insert feeler gage.
5. Rotate the magnet against the feeler gage.
6. Tighten the mounting screw.
7. The gage should pass between the foam pad and the magnet pole piece with moderate resistance.

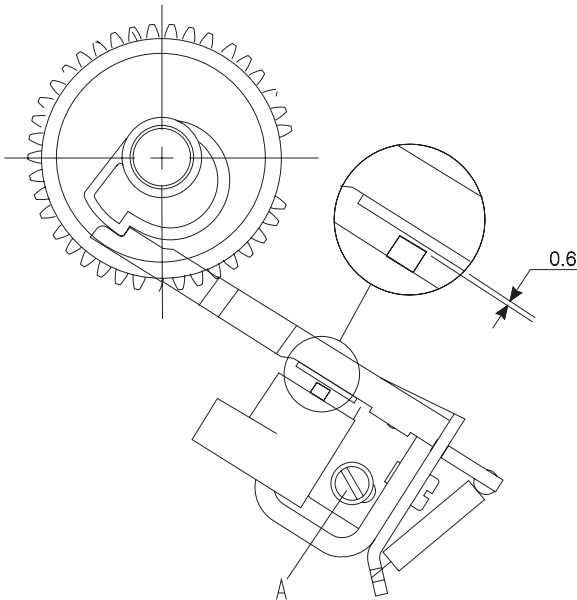

Optional Paper Feed Magnet

1. With the armature latched on the cam step check for $0.60 \text{ mm} \pm 0.07 \text{ mm}$ between the foam pad and the magnet pole piece. If adjustment is required, continue:
2. Keep the armature latched and loosen the magnet mounting screw [A].

Note: The flat side of the D-roll is down when the feed is latched.

3. Insert feeler gage.
4. Rotate the magnet against the feeler gage.
5. Tighten the mounting screw.
6. The gage should pass between the foam pad and the magnet pole piece with moderate resistance.

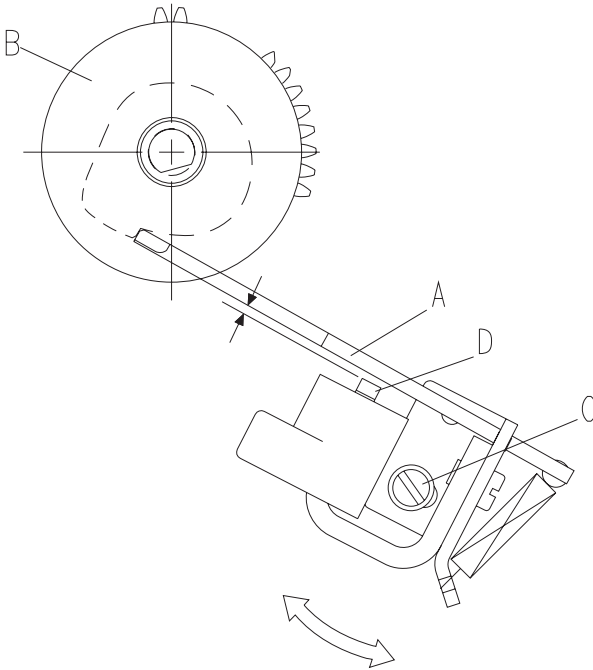

Printhead Skew - Level 1

1. Loosen the mounting screws [A].
2. Pivot the printhead around the shoulder screw [B] until the skew marks on the printout are parallel to the top edge of the paper. Use Print Test 1 or Quick Test to check this. Rotating the printhead clockwise will lower the left skew adjustment point on the test print.
3. Tighten the screws.
4. Install the top cover and print another page to verify the adjustment.

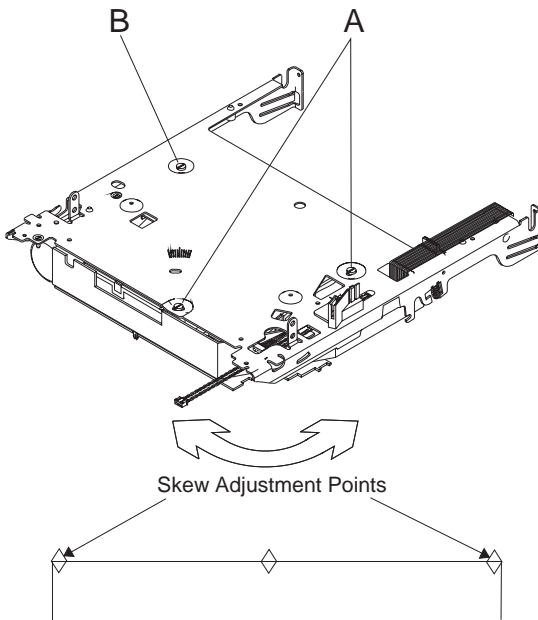

Printhead Skew - Level 2

1. Remove the top cover.
2. Loosen the screws [A].
3. Run Print Test 1 or the Quick Test on the Diagnostics Menu.
4. Move the pointer [B] to eliminate the skew. Moving the pointer toward the left raises the left adjustment point on the printout.
5. Tighten the screws, and verify the adjustment.

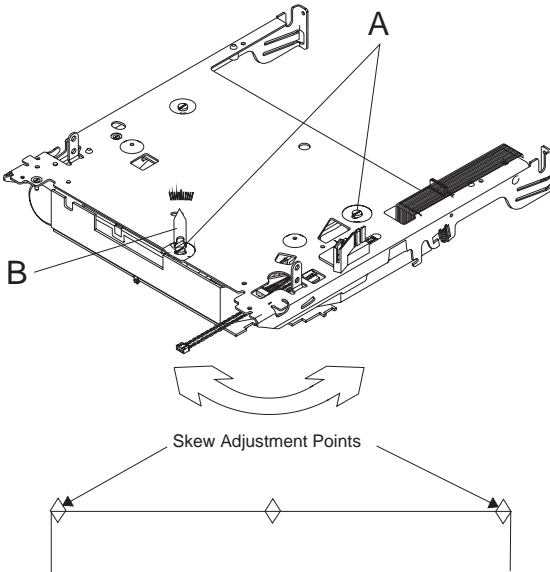

Print Registration Adjustment

Use Print Test 1 or the Quick Test to evaluate print registration. Adjust the registration so the tips of the diamonds are at the top and bottom edges of the page and the printout is centered left to right. Verify that the Top Margin is correct before adjusting the Bottom Margin.

1. Enter Diagnostics mode.
2. Select [Print Registration].
3. Select one of the following: [Left Margin], [Top Margin], or [Bottom Margin].
4. The value of the margin you selected is shown.
5. **Left Margin:** This margin can be set between -23 and +23. Changing the number by one moves the margin 1/75 inches. Moving the number in a positive direction moves the margin toward the right and negative moves the margin to the left.
6. **Top Margin:** This margin can be set between -20 and +20. Changing the number by one moves the margin by 1/75 inches. Moving the number in a positive direction moves the margin down the page and widens the top margin. Moving the number in a negative direction moves the text up the page and narrows the top margin.
7. **Bottom Margin:** This margin can be set between -7 and +7. Moving the number in a positive direction moves the margin down and narrows the bottom margin. Moving the number in a negative direction moves the text up the page and leaves a wider bottom margin.
8. Select [+] to move the number in a positive direction.
9. Select [-] to move the number in a negative direction.
10. Select [Print Test 1], or [Quick Test] to check your settings.
11. Select [Tray 1], or [Tray 2].
12. Select [Single], or [Continuous].
13. Select [SAVE] to save your settings when they are correct.
14. Press Return to return to the Diagnostics menu.

Removals

When there is artwork to support a procedure, it follows the text.

Covers

Right Cover Removal

1. Turn the printer off.
2. Remove all external trays.
3. Open the top cover.
4. Swing the cover open.
5. Remove the E-clip from the rear pivot pin and lift the cover off the rear pivot pin.

Front Cover Removal

1. Unplug the power cord.
2. Remove the paper tray.
3. Open the top cover.
4. Open the right cover.
5. Remove the Duplex mounting slot covers.
6. Release the latches **[B]**. You can reach the lower latches through the paper tray opening.
7. Pull the front cover forward, then move the cover to the right to separate the on/off switch linkage **[D]**.
8. Disconnect the ground strap from the frame on the left side.
9. Remove the front exit deflector switch.

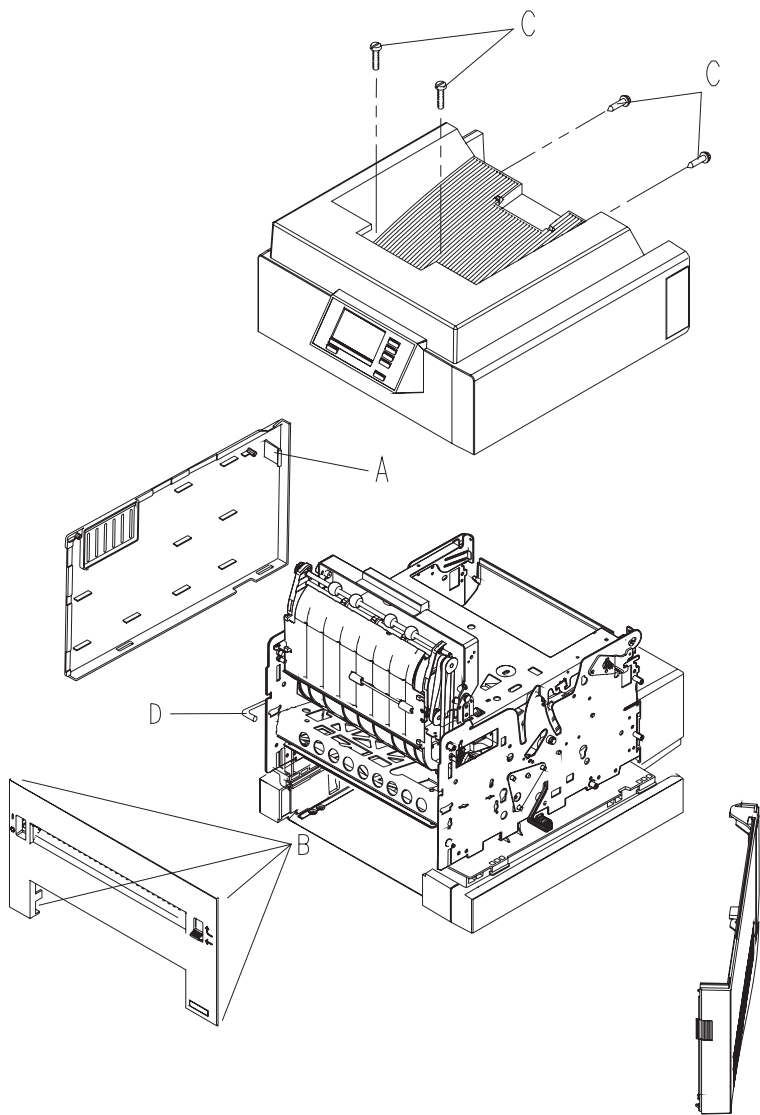

Left Cover Removal

1. Unplug the power cord.
2. Open the top cover and remove the print cartridge.
3. Remove the front cover.
4. Locate the latch [A] and push the end to the rear to release it.
5. Push the top of the cover to the left.
6. Remove the cover by sliding it to the rear of the machine.

Top Cover Removal

1. Remove the top cover screws [C].
2. Lift the rear of the cover first, then the front, and lift the cover off.
3. Rest the cover on the machine and disconnect the operator panel cable and the ground wire.

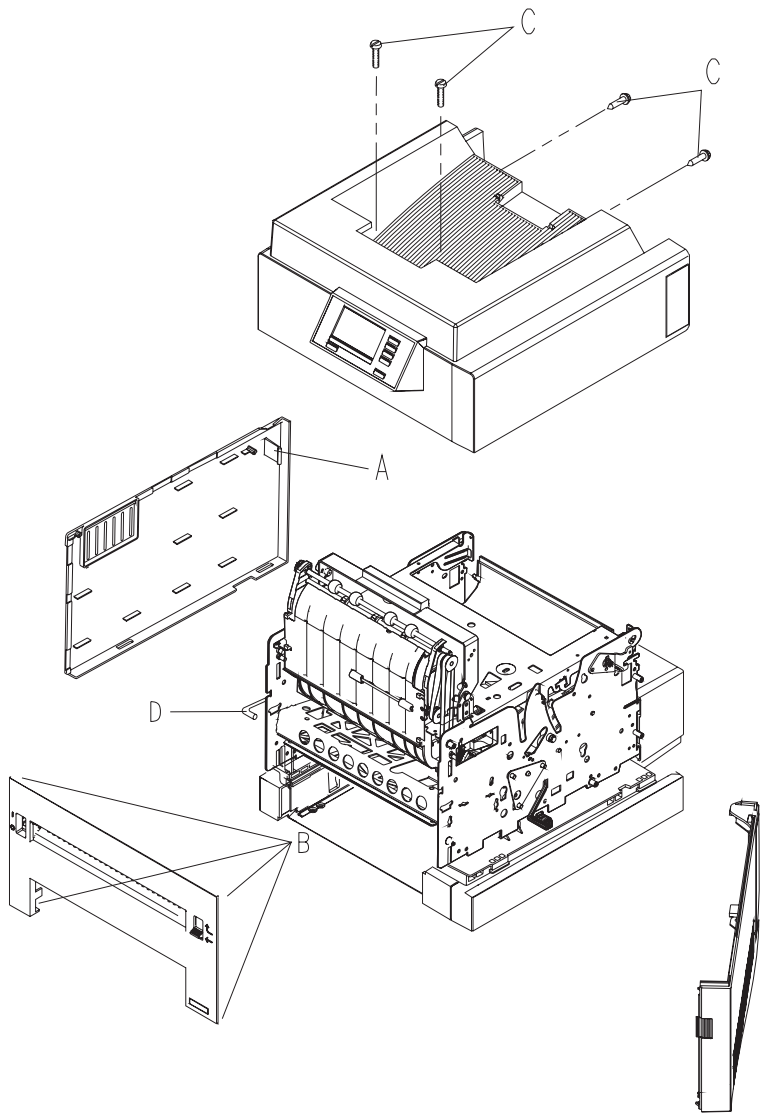

Transfer Roll Removal

1. Unplug the power cord.
2. Remove the print cartridge.
3. Remove the bearing cover from the left side of the transfer roll:

Note: Do not touch the transfer roll surface.

- Support the left bearing cover from the front with your left hand.
 - Use a small screwdriver to push the rear latch forward and release the bearing cover. This exposes the bearing on the end of the transfer roll.
4. Grasp the bearing on the end of the transfer roll. Lift slightly and move it to the left until the right end of the transfer roll shaft slides out of the right side bearing.
 5. Remove the transfer roll.
 6. Lift the right bearing straight up and out of the machine.

D-roll Assembly Removal

1. Unplug the power cord.
2. Remove the paper tray.

Note: The following 3 steps are not necessary, but may make it easier to see the parts.

3. Remove the print cartridge.
4. Remove the fuser input guide.
5. Remove the transfer roll housing assembly.
6. Move your finger down off the end of the shaft to the latch located above the flat part of the D-roll.
7. Push the latch down (away from the shaft) and slide the D-roll to the left, off the shaft.

Note: There is no positive detent when replacing the D-roll. Make certain the roll is in place by pulling toward the left without pushing the latch.

Note: Later machines do not have a latch. Remove the D-roll by pulling it firmly to the left. The D-roll without a latch is intended to be installed only once; if it is removed for any reason it should be replaced with a new one. The new D-roll may take considerable force to install.

Drive Motor Removal

1. Unplug the power cord.
2. Remove the system board.
3. Remove the system board inner EMC shield.
4. Remove the fuser input guide [A].
5. Remove the transfer housing assembly.
6. Remove the gear cover by releasing the rear latch and lifting up.
7. Remove screw [C] and the grounding clip (this clip is not present on all machines).
8. Remove the motor mounting nuts [B] and screws.
9. Work the motor out of the machine.

10P: Do not remove the motor from the gear bracket assembly; they are not available separately.

Installing the motor: If the motor has been removed from the gear bracket assembly, you must use the gear retaining plate as a template to be sure the motor pinion is correctly positioned to gear 4. Install the gear retaining plate to the gear bracket assembly and tighten the nuts. Install the motor to the assembly and tighten the screws. Remove the gear retaining plate from the assembly and install the motor in the printer.

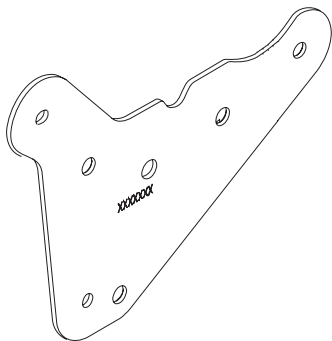

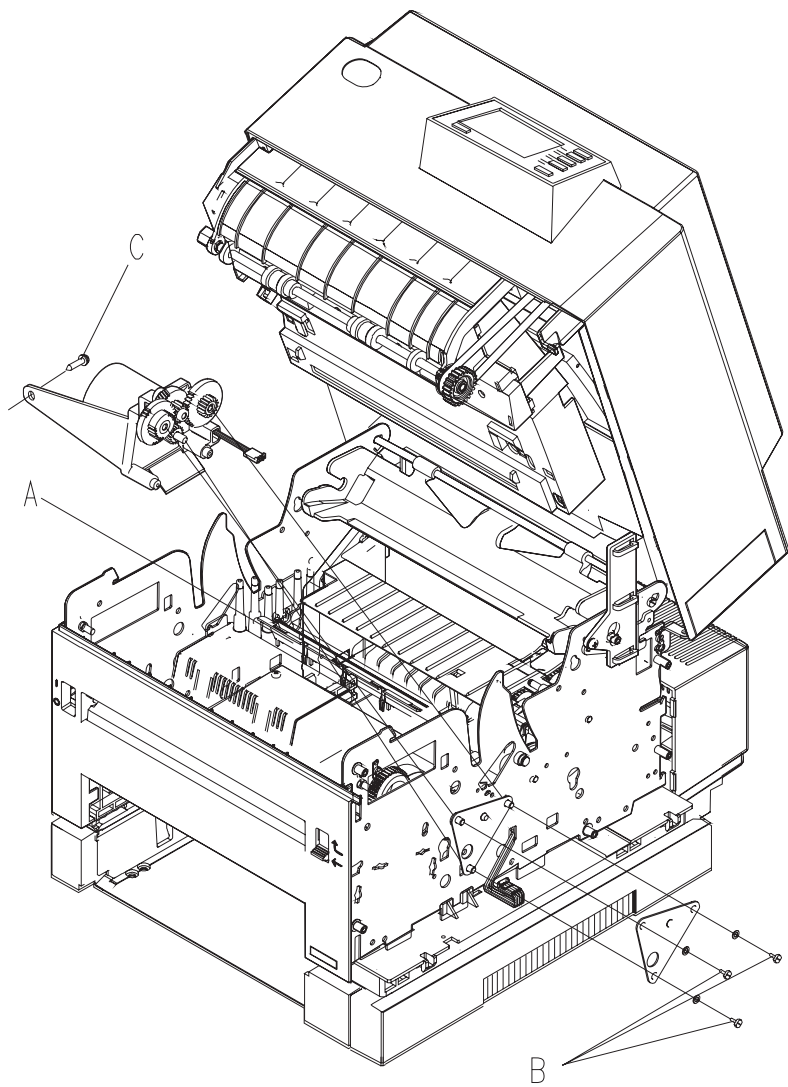

Fan/Redrive Removal

1. Open the top cover.
2. Remove the print cartridge.
3. Remove the top cover.
4. Remove the lower redrive shaft by disengaging the right end to the rear of the machine.
5. Disconnect the long redrive belt **[A]** and slip it off the lower shaft.
6. Remove the redrive assembly screws **[D]**.
7. Remove the plenum assembly and screws **[B]**.
8. Unplug the fan cable. The fan **[C]** can now be removed from the plenum assembly.

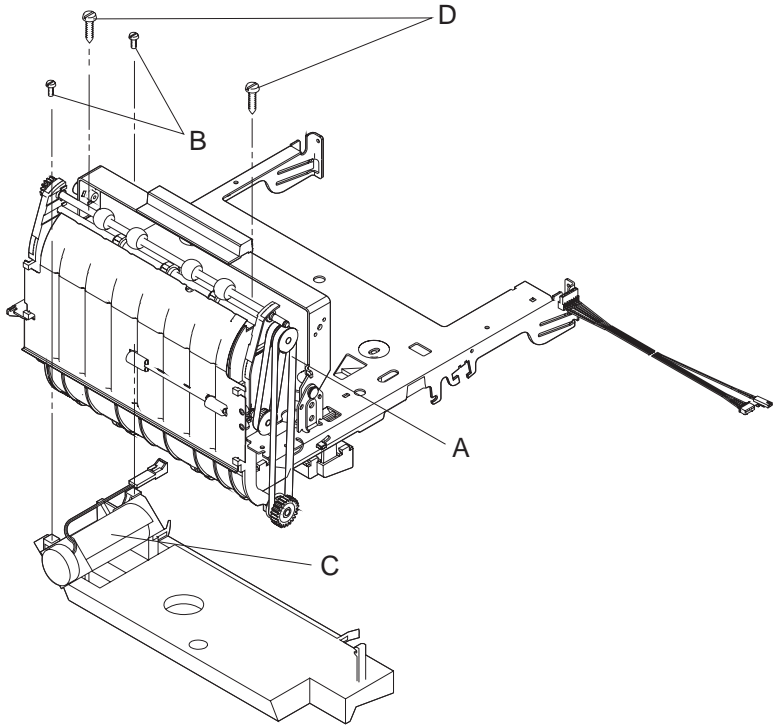

Fuser Removal

Note: The heater lamp is fragile and may be damaged if you are not careful when you remove or replace the fuser unit.

CAUTION: THE TEMPERATURE OF THE HOT ROLLER IS 150°-230°C (302°- 446° F). USE EXTREME CAUTION WHEN REMOVING THIS UNIT. BEFORE YOU SERVICE THIS UNIT, ALLOW THE MACHINE TO COOL FOR 5 MINUTES.

1. Unplug the power cord.
2. Remove the printer cartridge.
3. Disconnect the exit sensor cable from the fuser through the opening for the paper output.
4. Unsnap the front cover from the right side frame.
5. Remove the fuser cover.
6. Disconnect the power wires [A] from the left side of the fuser.
7. Remove the fuser input guide.
8. Completely loosen the four fuser mounting screws.
9. Lift the fuser out of the machine.

Fuser Input Guide Removal

1. Remove the fuser input guide [B] by lifting the rear end of the guide and unsnapping both sides from the fuser.
2. Lift the fuser input guide upward at both sides near the fuser and slide the guide toward the rear of the machine to release.
3. Lift the guide out of the machine.
4. Clean the fuser input guide before installing it.

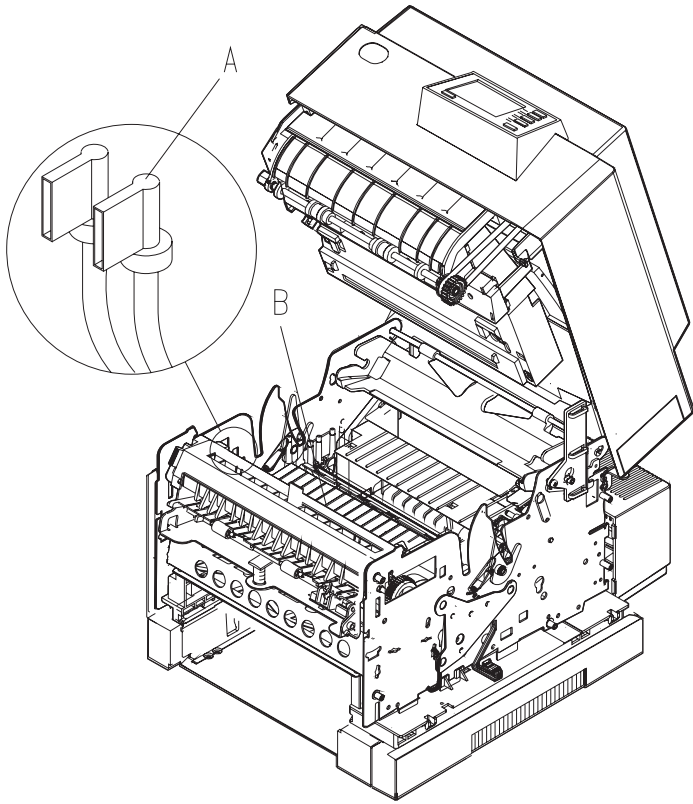

Fuser Lamp Removal

CAUTION: THE TEMPERATURE OF THE HOT ROLLER IS 150°-230° C (302°-446° F). USE EXTREME CAUTION WHEN REMOVING THIS UNIT. BEFORE YOU SERVICE THIS UNIT, ALLOW THE MACHINE TO COOL FOR 5 MINUTES.

Note: The fuser lamp is a glass heater. Do not touch the lamp with your hands; skin oils and acids can reduce the life of the heater lamp. Use a soft cloth to handle the heater lamp at all times if the lamp is to be reinserted.

1. Remove the fuser.
2. Remove the right lamp bracket [A].
3. Carefully pull the lamp [B] out to the right, using a soft cloth if the lamp is to be reinserted.

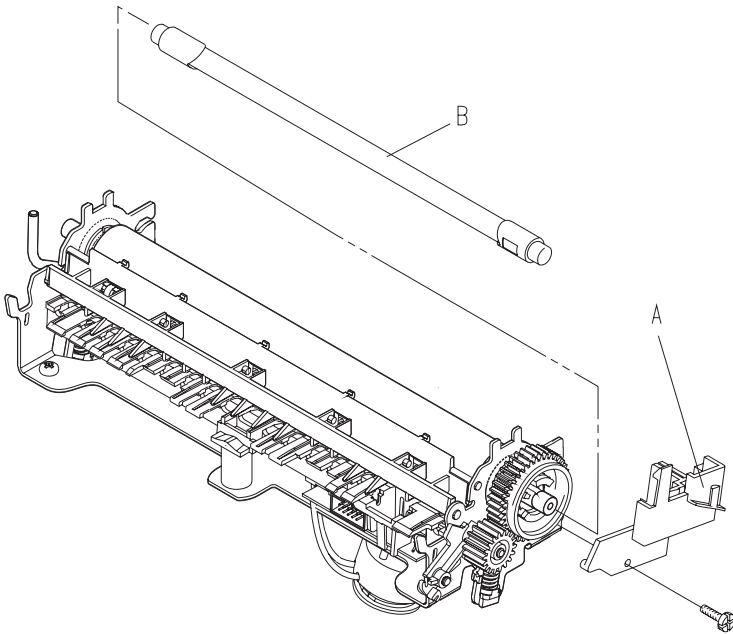

Fuser Solenoid Removal

1. Remove the fuser.
2. Remove the two mounting screws [A] holding the solenoid housing to the fuser housing.
3. Disengage the solenoid bracket from the plunger.

Note: When a new solenoid assembly is installed, the fuser solenoid must be adjusted.

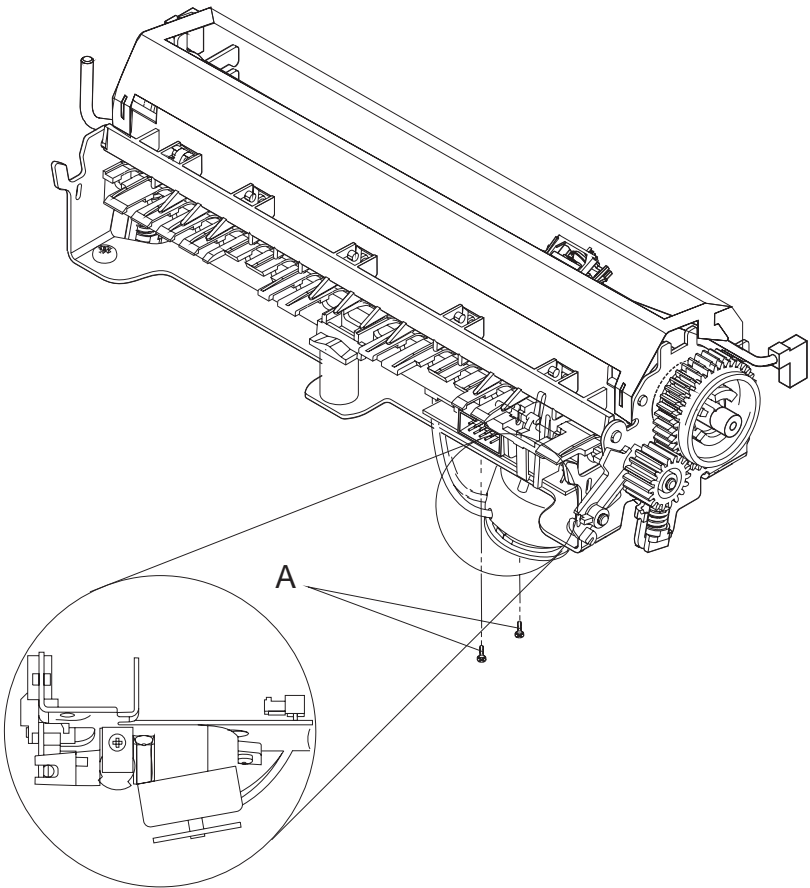

Fuser Thermistor Removal

1. Disconnect the thermistor cable connector **[A]** from the exit sensor card.
2. Remove the fuser cover and wiper.
3. Remove the tape holding the thermistor cable to the shroud.
4. Squeeze the thermistor bracket tabs **[B]** and remove the thermistor from the shroud.
5. Remove the thermistor cable from the guide clips on the right of the fuser to remove the thermistor.

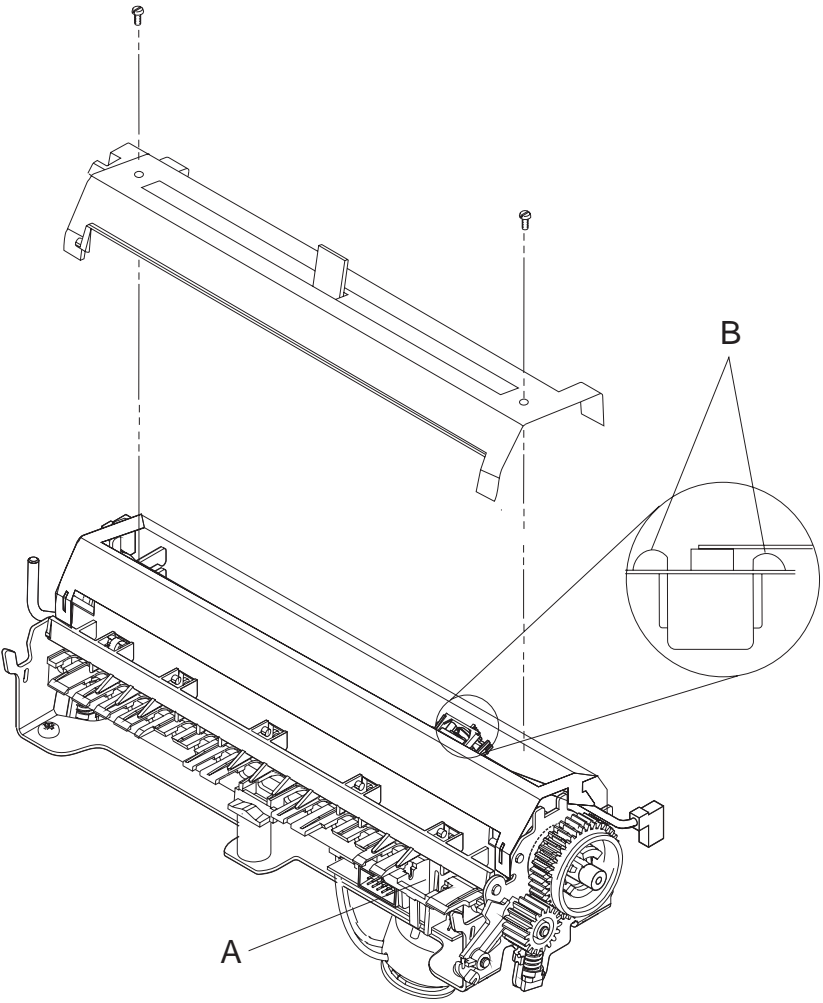

HVPS Removal

1. Unplug the power cord.
2. Remove the left cover
3. Remove the fuser input guide.
4. Remove the transfer roll housing.
5. Remove the fuser cover.
6. Disconnect the cable from the HVPS connector.
7. Remove the power switch rod.
8. Remove the ground screw **[B]**.
9. Remove the mounting screws **[C]**.
10. Pull the ground strap through the hole **[D]**.
11. The power supply is held in place by two latches on the left side.
To release the latches:
 - Push one latch **[E]** in and raise one of the studs **[F]** to release the latch.
 - Push the other latch **[E]** in and raise the other stud **[F]** to release the latch.
12. Lift the power supply until the studs **[F]** align with the large openings, then move the power supply to the right to release it from the frame.
13. Move the front of the power supply to the right (to clear the fuser power wires).
14. Tilt the front of the power supply up and lift it out of the machine

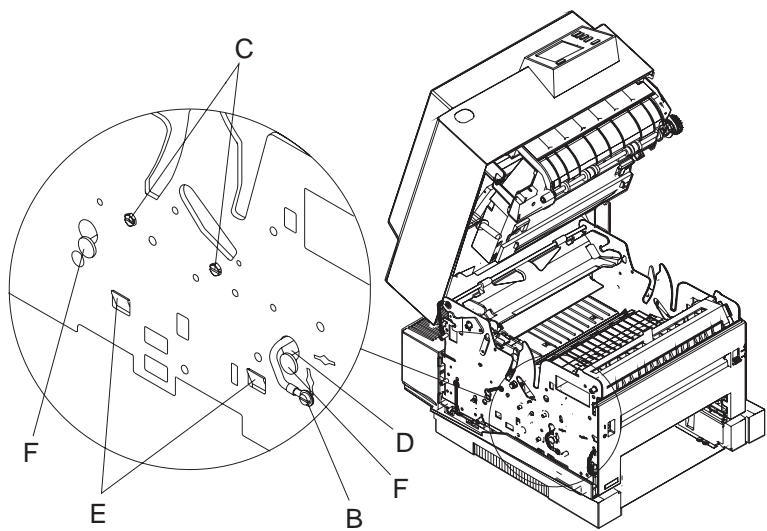

Input Sensor Removal

1. Remove the fuser input guide [A].
2. Remove the transfer roll housing.
3. Remove the D-roll.
4. Disconnect the system cable from the input sensor board.

Note: Use care, the flag can be damaged while removing the sensor.

5. Release latch [B] and pull the sensor down and forward to get it out of its mounting.
6. Disconnect the toner sensor cable from the board.
7. Remove the sensor board.

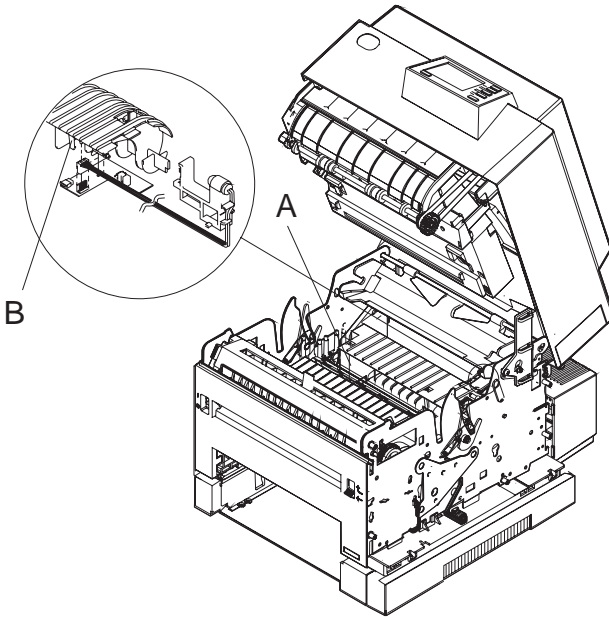

Lower Frame Assembly Removal

1. Remove the right, front, and left covers
2. Remove the LVPS and the rod for the on/off switch.
3. Remove gear cover and the fuser input guide [A].
4. Remove the transfer roll housing.
5. Disconnect the cable from the HVPS.
6. Remove the system board and the inner EMC shield.
7. Disengage the upper frame cables from the guide in the paper feed side frame.
8. Remove the screws [B].
9. Remove the fuser cover.
10. Unplug the fuser wires [C] and push them below the HVPS.
11. Unplug the paper size switch cable.
12. Lift the lower frame assembly straight up to separate it from the paper feed assembly.

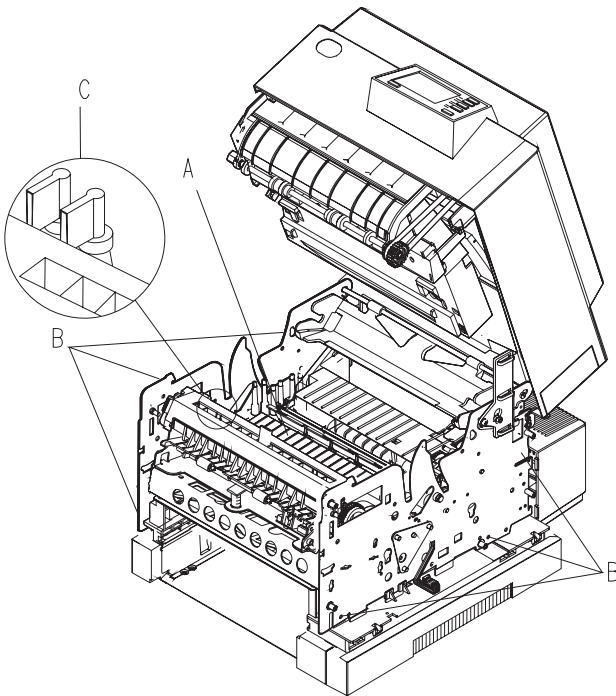

LVPS Removal

1. Disconnect the power cord.
2. Remove all external feed trays.
3. Remove the left and right side covers.
4. (10P and 16L) remove the system board and the inner EMC shield.
5. Remove the left and right LVPS mounting screws.
6. Disconnect the fuser connector [A].
7. Lift the supply up and then toward the right side frame to disconnect the On/Off switch linkage.

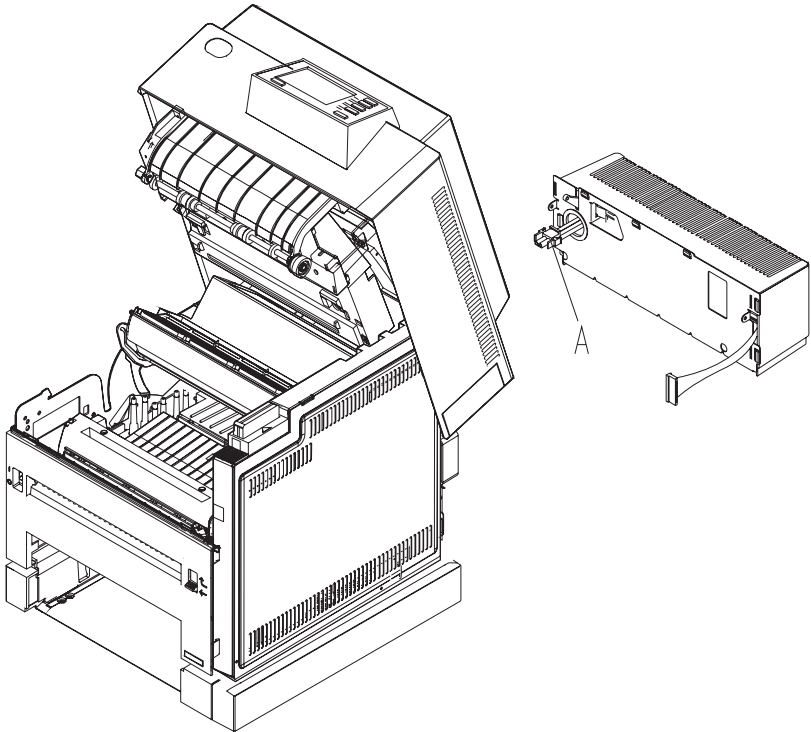

LVPS Cover Removal

1. Form tabs [D] away from the power supply to create clearance for tabs [A] to move downward.
2. Release the top latches [A].
3. Release the side latches [B].
4. Release the bottom latches [C].

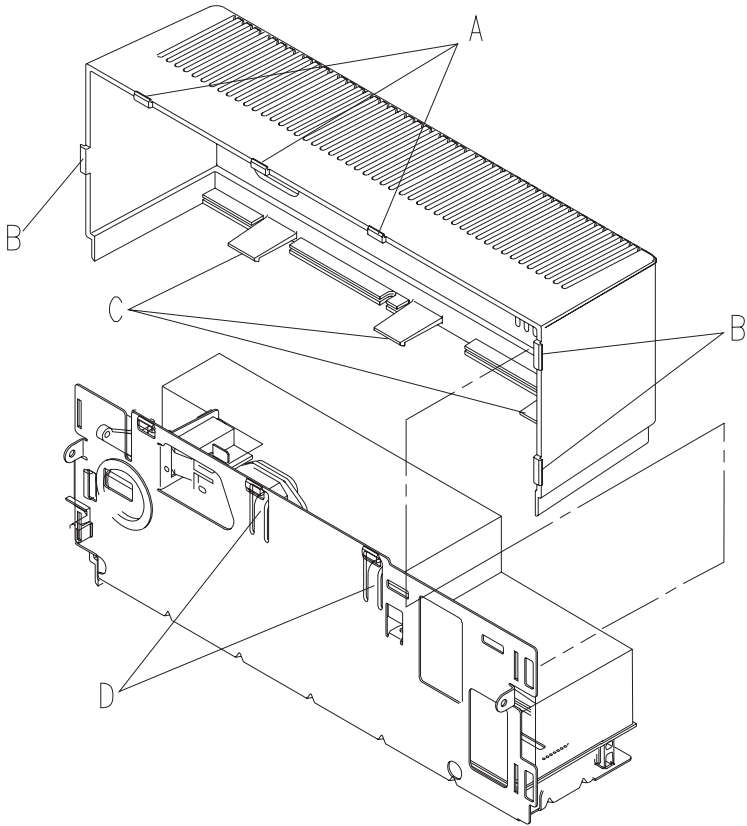

Operator Panel Removal

1. Remove the top cover.
2. Disconnect the operator panel cable.
3. Remove the operator panel mounting screws from the inside of the top cover.

Option Card Removal

1. Remove all external trays.
2. Open the top cover.
3. Open the right cover.
4. Remove the outer EMC shield.
5. Remove cable and mounting screws as required.
6. Pop the card off the plastic standoffs.

Exit Sensor Removal

1. Remove the front cover.
2. Disconnect the fuser/sensor cable.
3. Disconnect the thermistor cable.
4. Disconnect the fuser solenoid cable. This cable is not present in all models.
5. Release the latches [A].
6. Pull the sensor down to remove it.

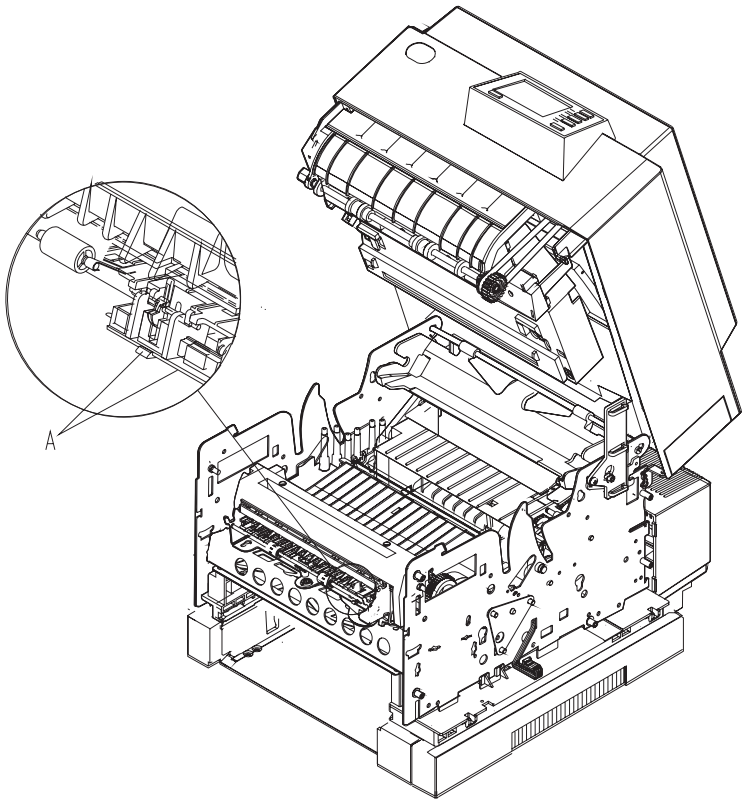

Paper Feed Magnet Assembly Removal

1. Remove the print cartridge.
2. Remove the right cover.
3. Remove the system board.
4. Remove the inner EMC shield.
5. Locate the paper feed magnet mounting screw **[B]** (visible through the right side frame **[A]**).
6. Remove the mounting screw **[B]**.
7. Remove the paper feed magnet assembly from the rear (slip the connector under the right frame).

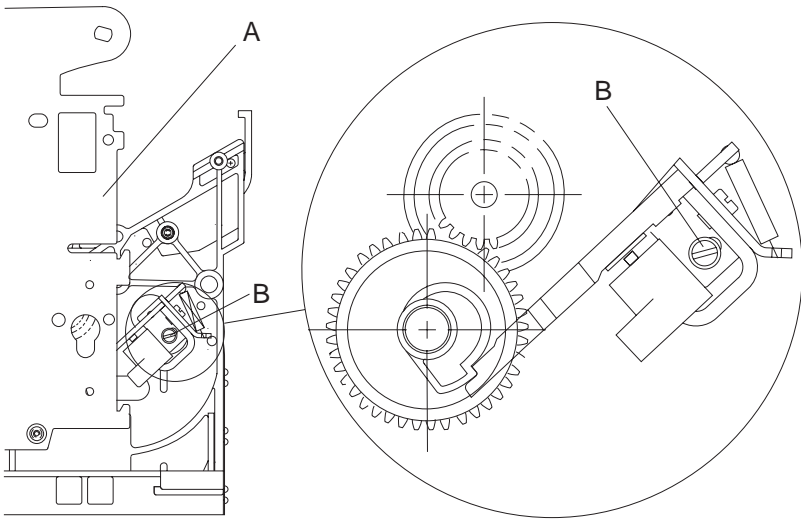

Paper Feed Rollers Removal

Note: Replace all paper feed drive rollers at the same time.

1. Remove the lower frame.
2. Disconnect the system cable from the input sensor.
3. Remove the screws [A] and the outer deflector.
4. Remove the screws [B] and the toner shield [E].
5. Separate the side frames.
6. Pull the guides [C] out of the side frames.
7. Use a flat-blade tool to snap the gears and rollers [D] off the shaft.

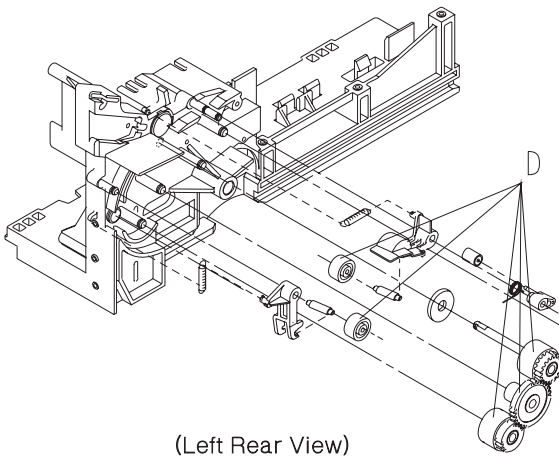
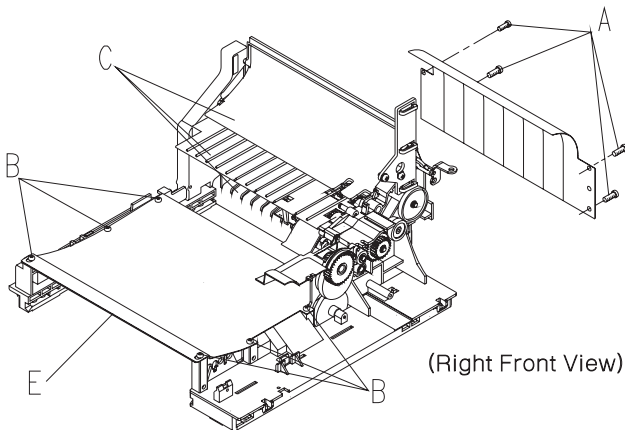

Paper Size Switch Removal

1. Open the top cover.
2. Remove the print cartridge.
3. Remove the paper tray.
4. Open the right side cover.
5. Remove the front cover.
6. Remove the two screws [A].
7. Unplug the cable [B] from the switch connector [C].
8. Rotate the switch about 90° and pull it out of the printer.

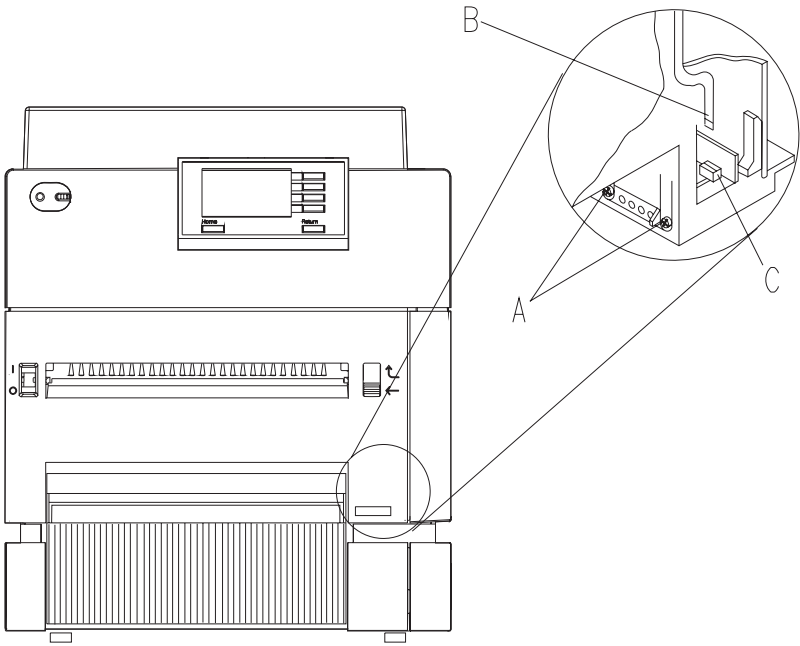

Printhead Removal

IMPORTANT: The printhead is ESD-sensitive. It is not serviceable and should be replaced as a unit.

1. Turn the printer off.
2. Remove the print cartridge.
3. Remove the right and top covers.
4. Remove the exit redrive and its belt.
5. Remove the air plenum.
6. Remove the screws [A] and the pointer if present.
7. Cut and discard the printhead cable clamp.
8. Disconnect the connectors [B].
9. Remove the printhead and the printhead shroud.
10. Pry off the grip rings holding the printhead to the shroud.

Note: After replacing the printhead perform the printhead skew adjustment.

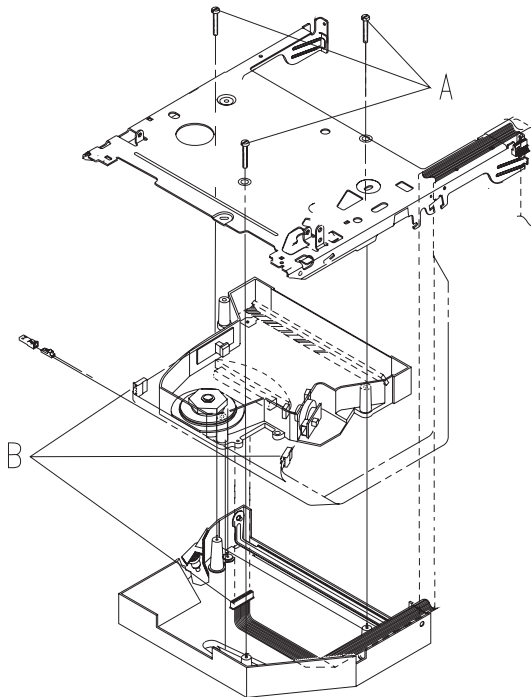

System Board Removal

1. Check the page count and write it down so you can set the new system board.
2. Turn the printer off.
3. Remove the right cover.
4. Remove the outer EMC shield by pressing down on the two bottom tabs, slide the shield forward, then down (10P has no outer EMC shield).
5. Disconnect all the external connectors from the system board and remove the option cards.
6. Remove the system board mounting hardware [A].
7. Release the system board standoff.
8. Remove screw [B]. and remove the system board.

Note: If system board is being replaced, remove the ROM SIMM and all options for installation on the new system board.

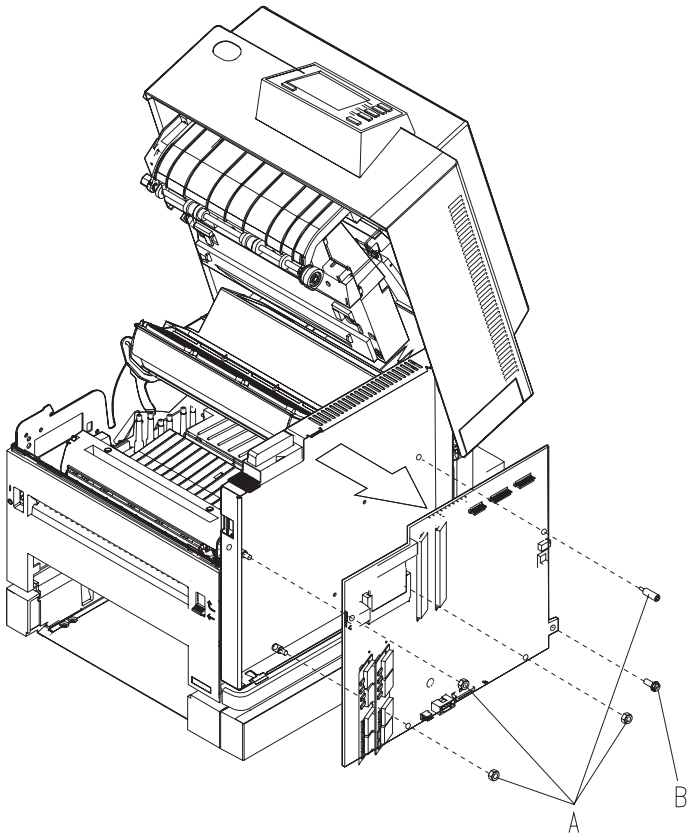

System Cable Removal

1. Turn the printer off.
2. Remove the right cover.
3. Remove the transfer roll housing.
4. Remove the fuser input guide.
5. Disconnect the system cable connections.
6. Remove the cable through the top of the machine.

Fuser/Sensor Cable Removal

1. Turn the printer off.
2. Remove the system board.
3. Remove the inner EMC shield.
4. Disconnect the cable from the exit sensor board.
5. Remove the front cover.
6. Remove the front exit deflector switch.
7. Disconnect the cable from the paper sensor assembly.
8. Remove the cable through the right frame.

Torquer Motor Removal (10P)

1. Remove the lower frame assembly from the base.
2. Remove the D-roll.
3. Remove the D-roll shaft/gear assembly, taking care not to lose the two bushings.
4. Remove the two screws and remove the torquer motor and adapter.
5. Unsnap the adapter from the motor.

Note: When reinstalling, align the timing marks on the torquer motor gear and D-roll gear.

Toner Sensor Removal

1. Remove the fuser input guide [A]
2. Remove the transfer roll housing.
3. Lift the input sensor board far enough to disconnect the cable [B].
4. Remove the end of the bellcrank spring.
5. Lift the sensor to unsnap it.
6. Work the cable out of the frame and remove the sensor.

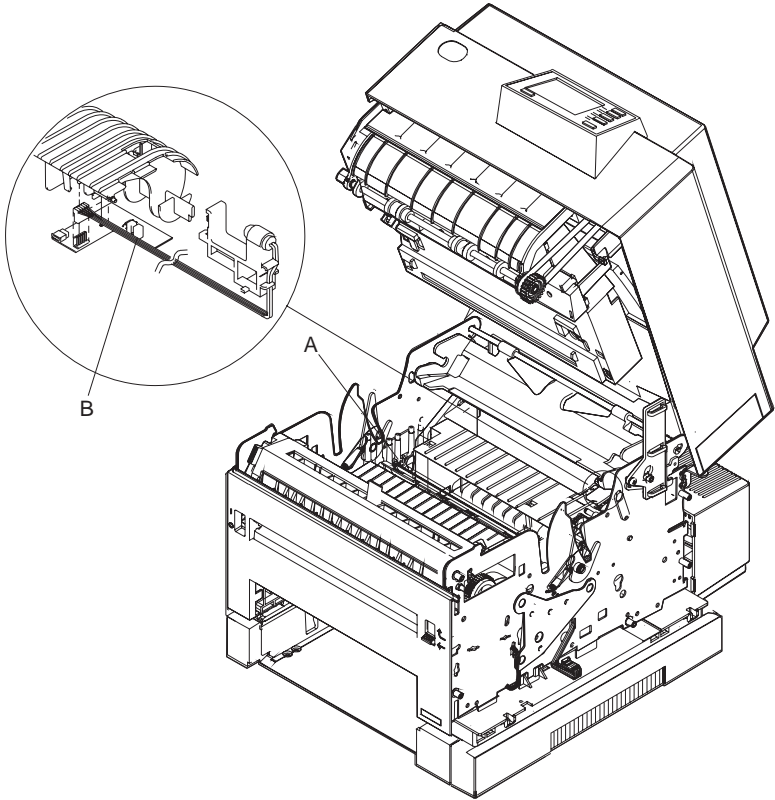

Transfer Roll Housing Removal

1. Remove the print cartridge.
2. Remove the fuser input guide.
3. Grasp the housing and pull toward the front of the machine to disconnect the housing from the mounting studs, visible through openings **[B]** in the inner deflector.
4. Lift the transfer roll housing far enough to disconnect the system cable.
5. Lift the transfer roll housing out of the machine.
6. To replace the transfer roll housing, perform the removal procedure in reverse order. After replacing the Transfer Roll Housing, open the top cover, power the machine off then on, to ensure the erase lamps flash off and on.

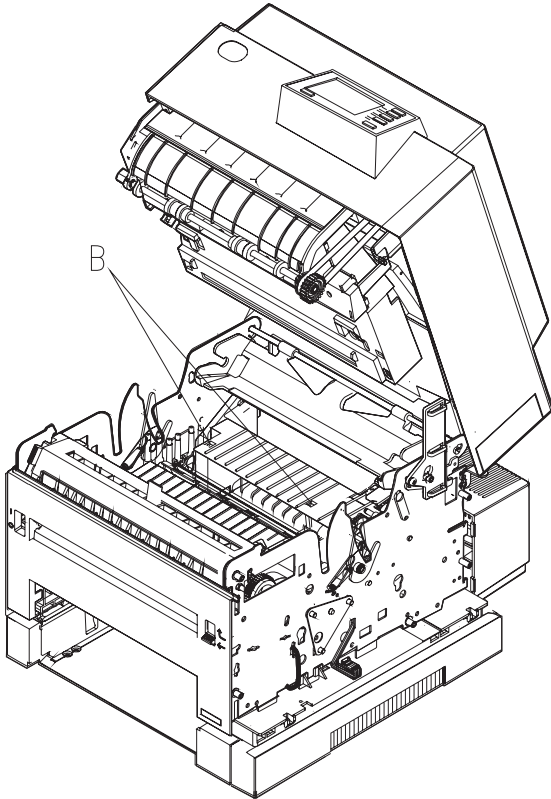

Upper Frame Removal

1. Unplug the power cord.
2. Remove the print cartridge.
3. Remove the right, left, and top covers.
4. Remove the system board.
5. Remove the inner EMC shield.
6. Remove the load box latches [A].
7. Release the latches [B].
8. Pivot the upper frame to the rear to release the spring tension.
9. Unsnap the plastic insert [D] holding the upper frame cables in the right side frame.
10. Remove the screws [C].
11. Remove the upper frame cables through the side frame.
12. Lift the upper frame off the machine.

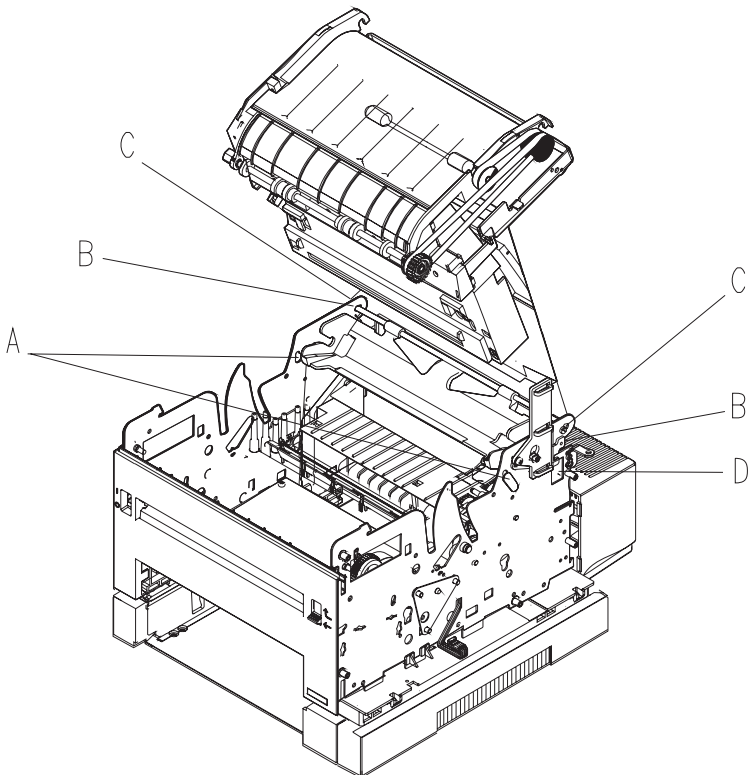

Zif Connector Removal

1. Slide the cable clamp [A] to the open position.
2. Note how the contact surfaces [C] of the cable are positioned as you pull the cable [B] out of the connector.

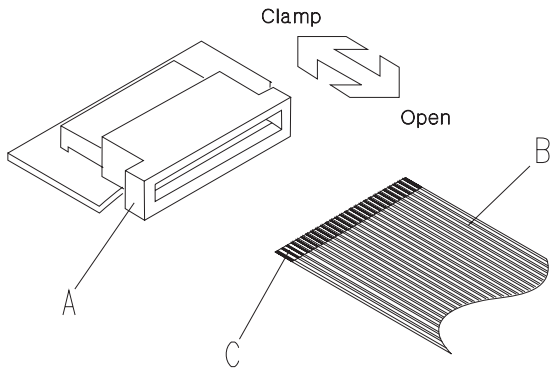

Duplex Option Top Cover And Table Cover Removal

1. Open the top cover by pulling up at [A] and pivoting 90°.
2. Pry the top cover from the bottom cover at [B] and lay the top cover on its side.
3. To disconnect the fan leads, the table cover has to be removed.
4. Release latches [C] on the paper table cover and lift up. Release latch [D] and lift the paper table cover out of the frame assembly.

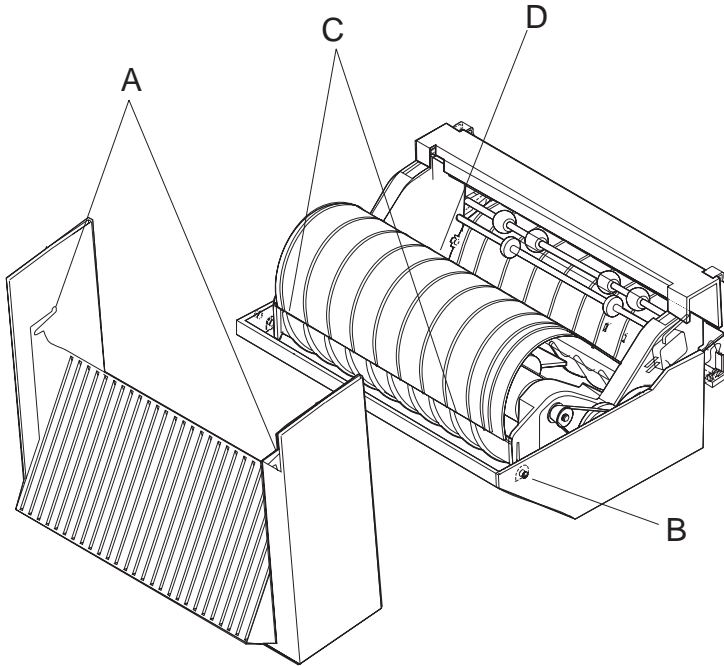

Duplex Option Exit Card And Cover Removal

1. Pry up on tabs [A], after the tabs are released, lift up on the cover, rotate the cover out, and slide it to the right to completely remove it.
2. Disconnect the exit sensor card cable.
3. Depress the exit sensor flag actuator [B] and lift out the exit sensor card.

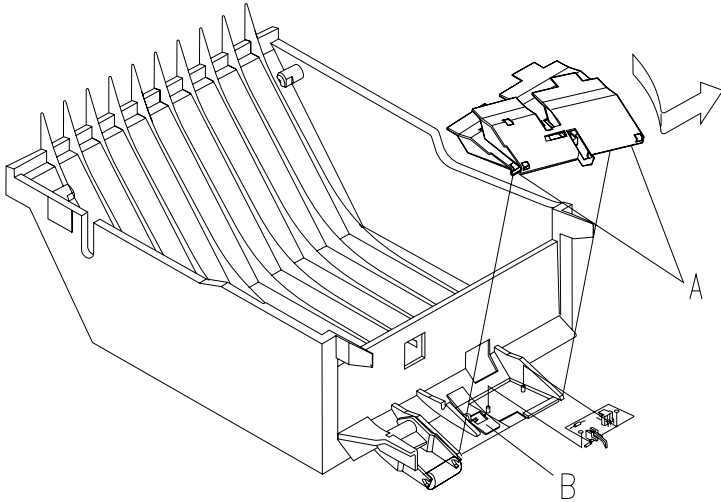

Duplex Option Bottom Cover And Entry Sensor Card Removal

1. Release the two latches [A] on the frame assembly and lift it out of the bottom cover.
2. Pry up on the sensor card at [B], so it will clear the mounting stud, and pull it out of the frame assembly.

Note: When re-installing the sensor, lift up the flags so they will clear the sensor and not be damaged.

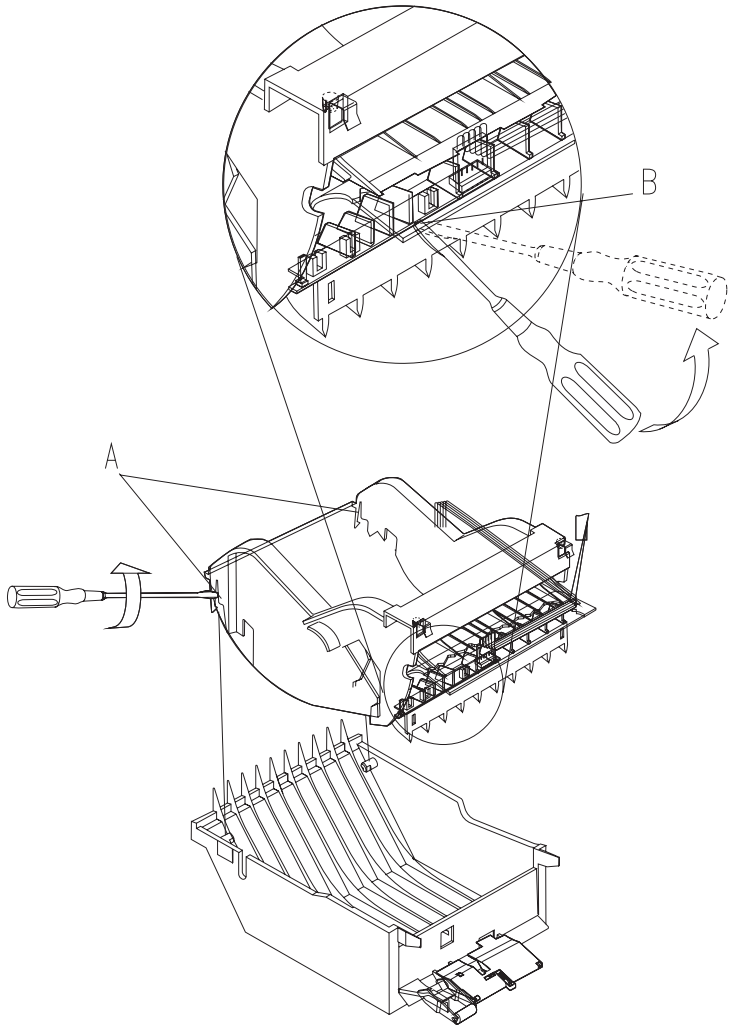

Duplex Option System Card And Motor Removal

1. Disconnect all cables.
2. Release latches [A] and lift the system board out.
3. Remove the two motor mounting screws [B].
4. Lift the motor out of the frame assembly.

Note: The remaining FRU is the Gearblock Assembly. When you replace this FRU see “Lubrication Specifications” on page 121”.

Note: Reinstall the motor so the belt is not tight but will not jump teeth on the timing pulley.

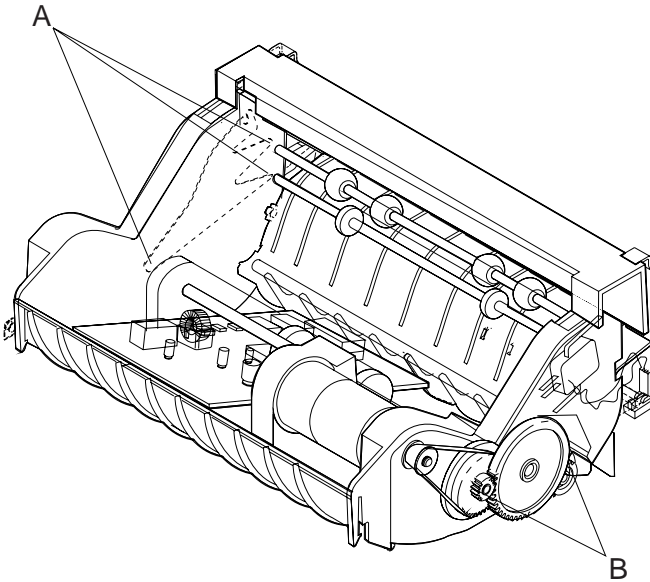

Connector Locations

This chapter shows the locations of major printer assemblies, gears, connectors, and ground straps.

Major Assembly Locations

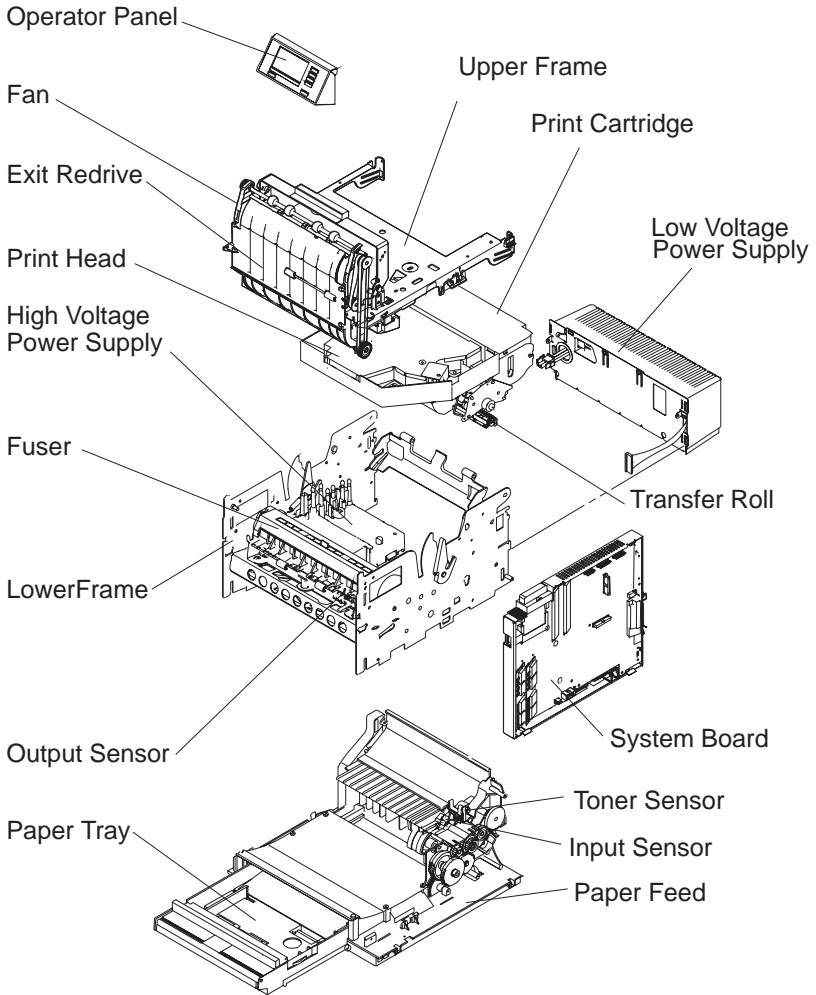

Gear Train

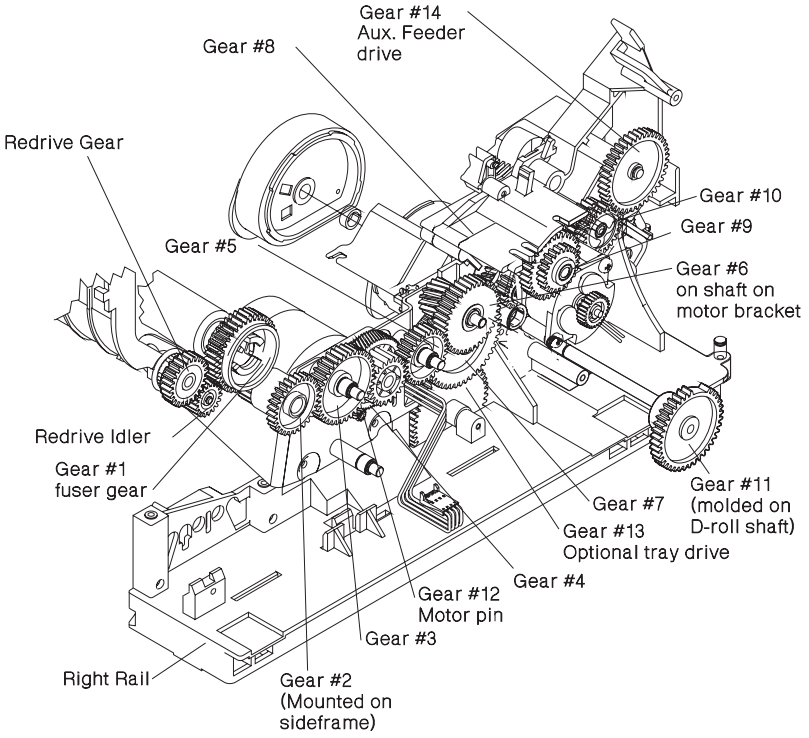

HVPS

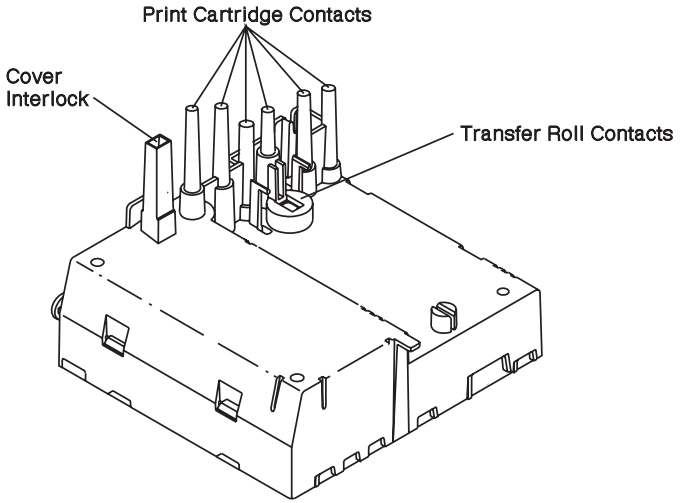

Transfer Roller Housing

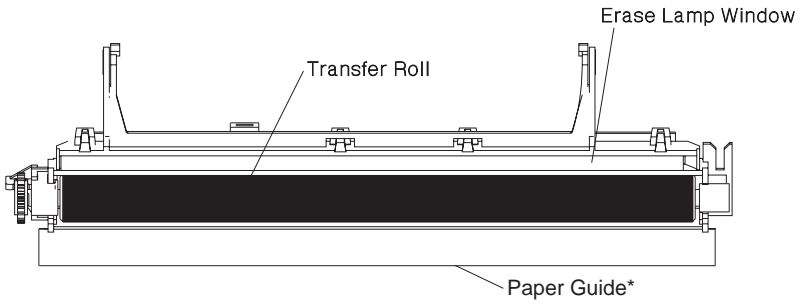

* Transfer roller housing for 10P has no paper guide

System Cable

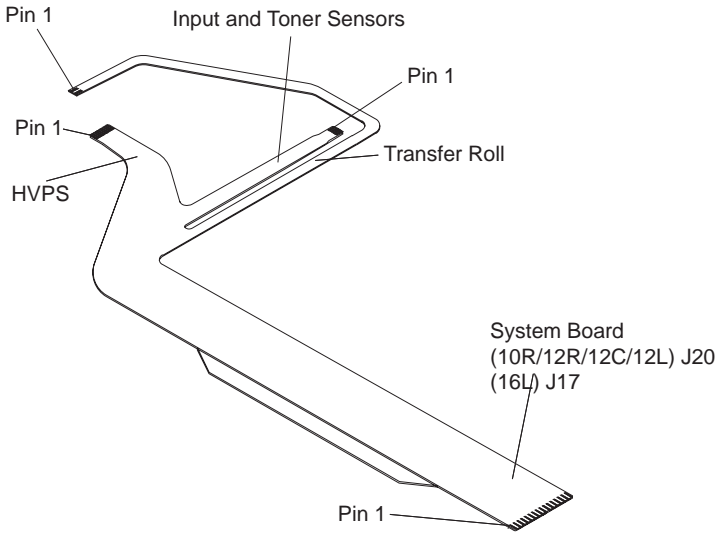

System Board Connectors 10R/12R/12L

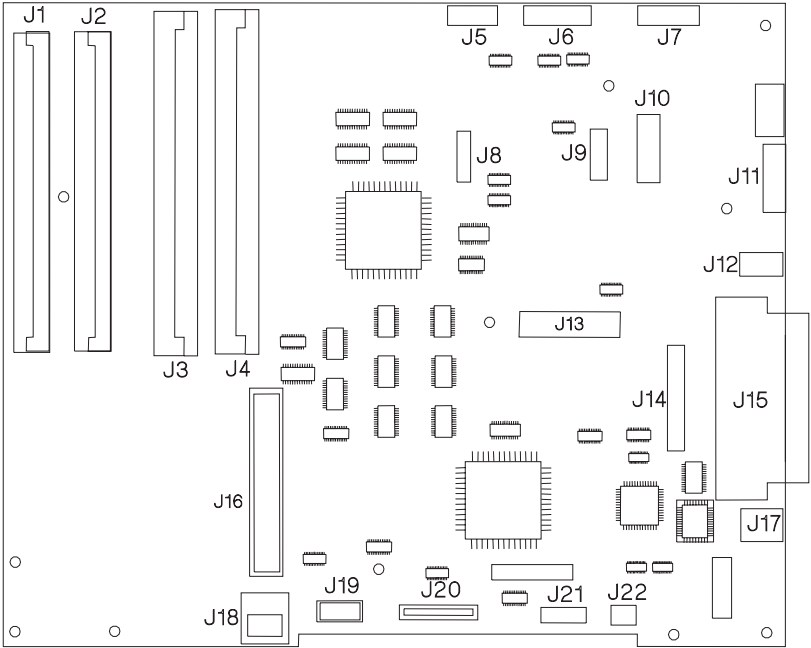

System Board Connectors 10R/12R/12C/12L	
Connector	Name
J1	DRAM SIMM
J2	DRAM SIMM
J3	ROM SIMM (flash memory option)
J4	ROM SIMM (printer microcode)
J5	Printhead Mirror Motor(Printhead)/ Fan
J6	Laser (Printhead)/ Hsync
J7	Operator Pane/Output Bin Sensor
J8	DC to DC Convertor
J9	DC to DC Convertor
J10	INA Power Card
J11	LVPS
J12	Envelope Feeder Magnet
J13	INA Card
J14	Serial
J15	Parallel Port
J16	Font Card
J17	500 Sheet Option
J18	Duplex
J19	Fuser
J20	HVPS Flex (Includes input and toner sensors and erase lamps on transfer roller)
J21	Paper Drive Motor
J22	Paper Pick Magnet

System Board Connectors 16L

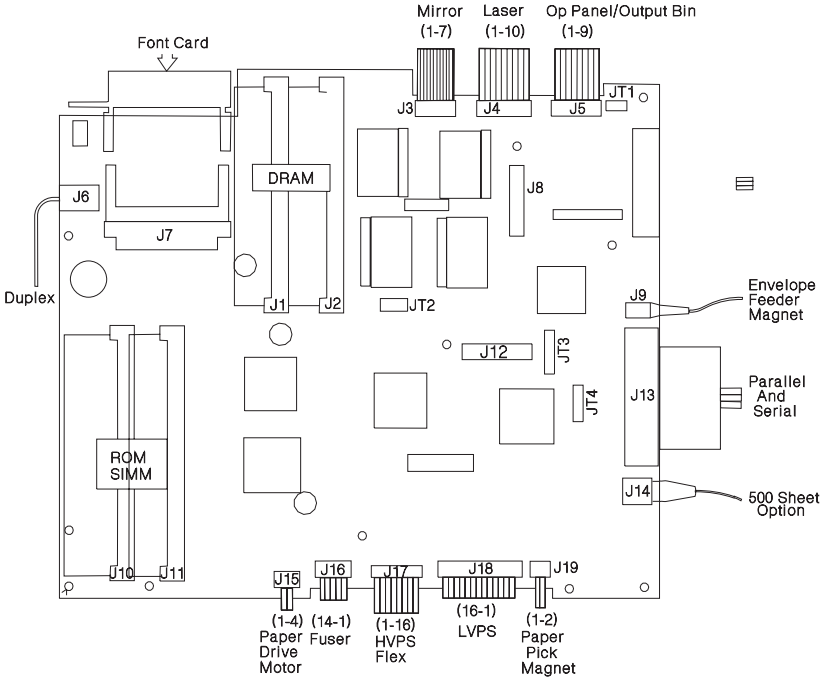

System Board 16L	
Connector	Name
J1	DRAM SIMM
J2	DRAM SIMM
J3	Mirror Motor(Printhead)/ Fan
J4	Laser (Printhead)/ Hsync
J5	Operator Pane/Output Bin Sensor
J6	Duplex
J7	Font Card
J8	Hard Disk Option
J9	Envelope Feeder Magnet
J10	ROM SIMM (Printer microcode)
J11	ROM SIMM (flash memory option)
J12	INA Card
J13	Parallel and Serial Port
J14	500 Sheet Option
J16	Paper Drive Motor
J16	Fuser
J17	HVPS Flex (Includes input and toner sensors and erase lamps on transfer roller)
J18	LVPS
J19	Paper Pick Magnet

System Board Connectors 10P

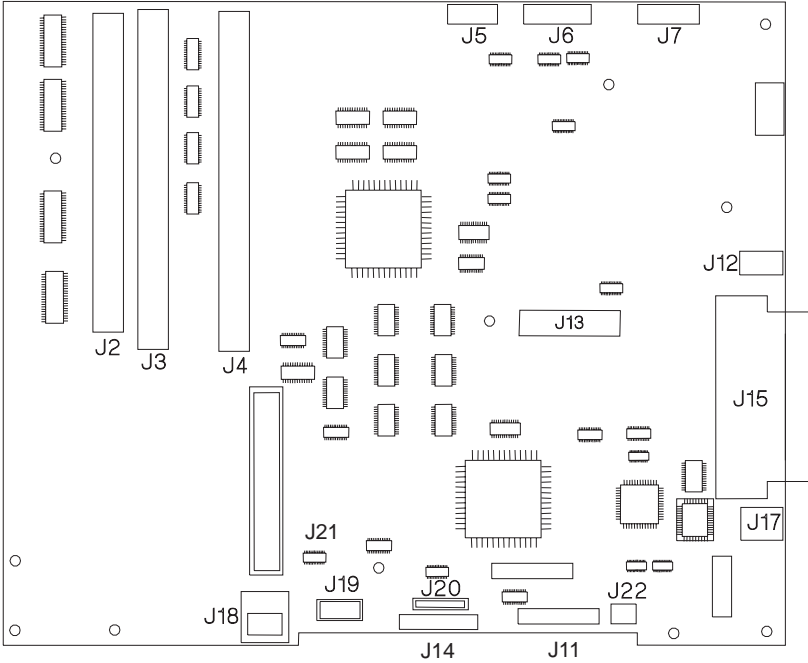

System Board 10P	
Connector	Name
J1	N/A
J2	DRAM SIMM
J3	Option SIMM (flash memory option)
J4	ROM SIMM (printer microcode)
J5	Printhead Mirror Motor/Fan
J6	Printhead Hsync/Laser
J7	Operator Panel
J8	N/A
J9	N/A
J10	N/A
J11	LVPS
J12	Envelope Feeder Magnet
J13	INA/Hard Disk
J14	HVPS
J15	Parallel Port
J16	N/A
J17	Second Paper Tray Option
J18	Duplex
J19	Exit & Paper Size Sensor/Fuser Solenoid
J20	Input & Toner Sensor Board/Erase Lamps
J21	Drive Motor
J22	Torquer Motor (Tray 1 pick)

Printhead Cables

The printhead cable connector for 10P, 10R, 12R, 12L, and 12C is J6. The printhead cable connector for 16L is J4.

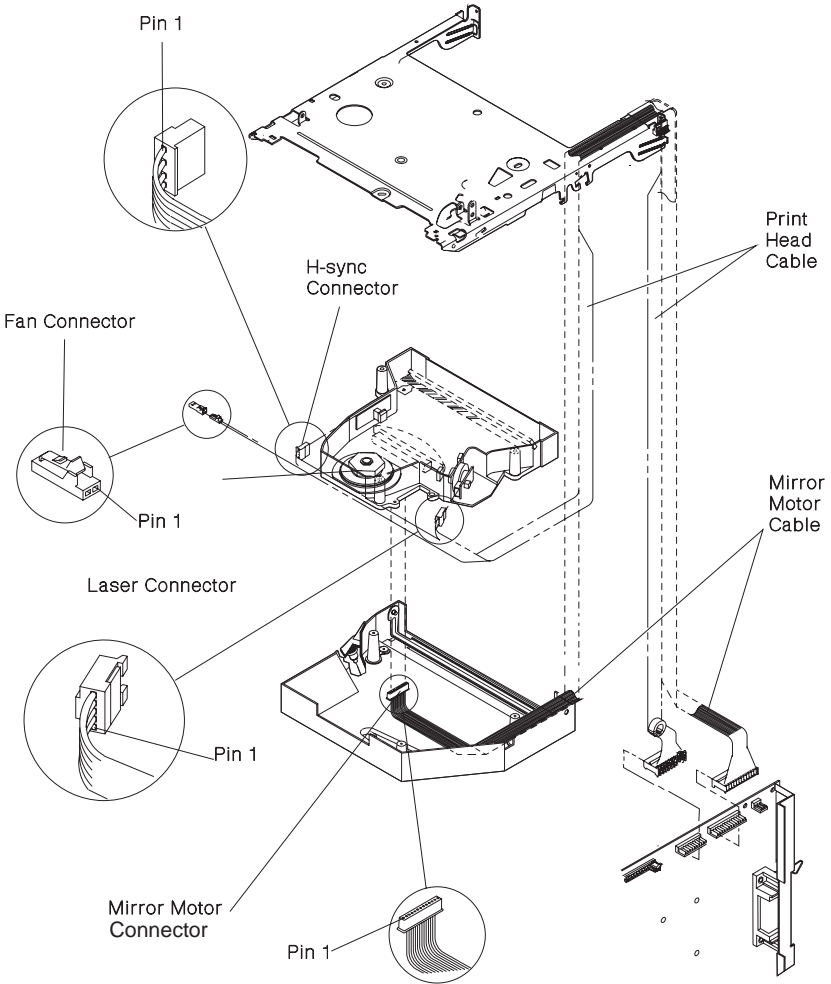

Printhead Cable		
Pin	Laser	Hsync
1		1
2		2
3		3
4		4
5	6	
6	5	
7	4	
8	3	
9	2	
10	1	

Mirror Motor Cable/Fan Cable

The mirror motor cable connector for the 10P, 10R, 12R, 12L, and 12C is J5. The mirror motor cable connector for 16L is J3.

Pin	Motor	Fan
1	1	
2	2	
3	3	
4	4	
5	5	
6		2
7		1

Operator Panel/Output Bin Sensor Cable — Handle-Mounted Outbin Sensor

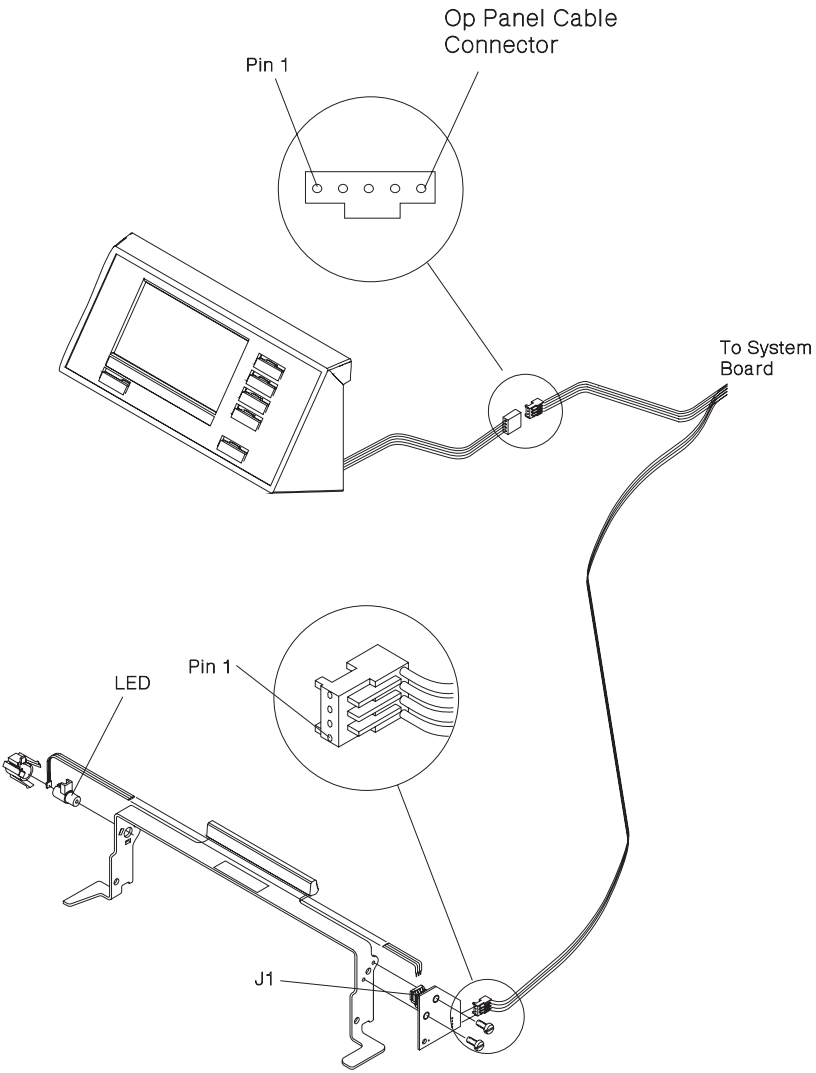

Operator Panel/Output Bin Sensor Cable — Redrive-Mounted Outbin Sensor

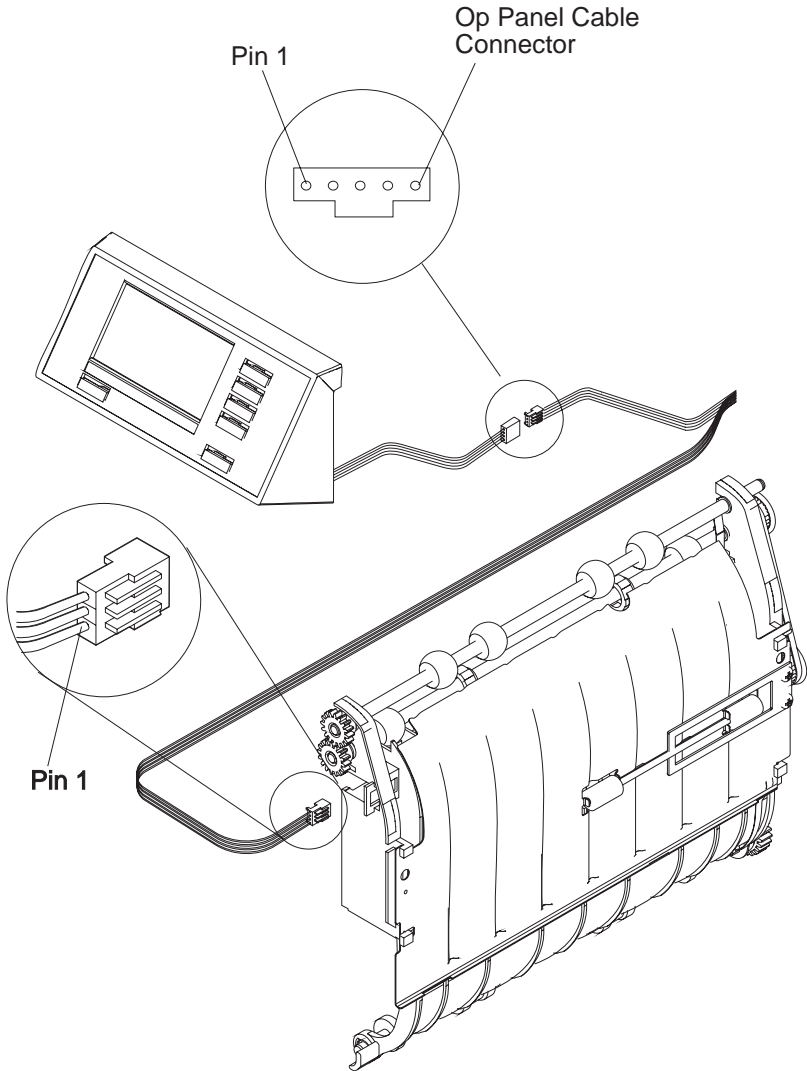

The cable connector for 10P, 10R, 12R, 12L, 12C is J7. The cable connector for 16L is J5.

Pin	Op Panel	Sensor
1	1	
2	2	
3	3	
4	4	
5	5	
6		1
7		2
8		3
9		4 *

* No connection on machines with redrive-mounted output bin sensor.

Printer Ground Straps

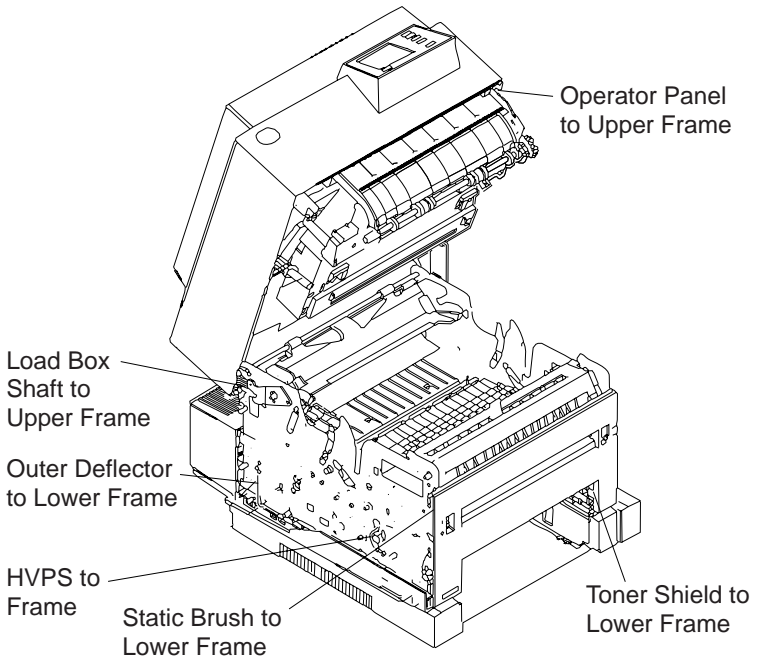

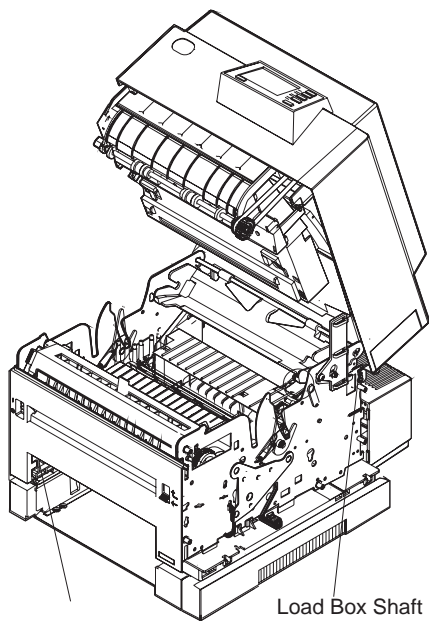

Toner Shield
to Lower Frame

Load Box Shaft
to Upper Frame

Preventive Maintenance

This chapter describes procedures for printer preventive maintenance. Following these recommendations can help prevent problems and maintain optimum performance.

Safety Inspection Guide

The purpose of this inspection guide is to aid you in identifying unsafe conditions.

Use good judgment to identify possible safety conditions not covered by this inspection guide. Refer to the safety reminders for a general checklist.

If any unsafe conditions exist, find out how serious the hazard could be and if you can continue before you correct the hazard.

Check the following items:

- Damaged, missing, or altered parts, especially in the area of the On/Off switch and the power supply
- Damaged, missing, or altered covers, especially in the area of the top cover and the power supply cover
- Possible safety exposure from any non-Lexmark attachments

Lubrication Specifications

Lubricate only when parts are replaced or as needed, not on a scheduled basis. Use of lubricants other than those specified can cause premature failure. Some unauthorized lubricants may chemically attack polycarbonate parts. Use IBM no.10 oil PN 1280443 (approved equivalents: Mobil DTE27, Shell Tellus 100, Fuchs Renolin MR30) to lubricate the areas of contact between:

- Gear no. 2 and its stud on the side plate
- Gear no. 3 and its stud on the motor bracket
- Gear no. 4 and its thrust washer
- Gear no. 4 and its stud on the motor bracket
- Gear no. 5 and its stud on the motor bracket

- Gear no. 6 and its stud on the motor bracket
- Gear no. 6 and its thrust washer
- Gear no. 7 and its stud on the rail
- Gear no. 7 and its thrust washer
- Gear no. 8 and its stud on the rail
- Gear no. 8 and its thrust washer
- Gear no. 9 and its stud on the rail
- The metering roller shaft and its bushings on the rail assembly
- The main metering backup roller and its stud and thrust washer
- The D-roller shaft and its bushings on the rail assembly
- The auxiliary metering roller and its stud on the rail, including the snap-in groove and the snap ridges in the roller hole
- Gear no. 14 and its stud on the rail
- Gear no. 13 and its stud on the rail
- The auxiliary paper feed idler and its stud on the rail
- The prealigner drive idler and its stud on the rail
- The prealigner drive roller and its stud on the rail
- The prealigner backup roller and its shaft and thrust washer
- The fixed-center idler gear in the 500 sheet base and its shaft
- The idler gear in the 500 sheet base and its shaft

Use IBM no. 23 grease (approved equivalent Shell Darina 1) to lubricate:

- Front pivot latch studs
- Gear no. 8 teeth at gear no. 7 contact points
- Gear no. 9 teeth at gear no. 11 contact points
- Gear no. 9 teeth at gear no. 8 and gear no. 10 contact points
- Cover Hinge Spring tips
- Cartridge “ramps” at top center of both sides frames
- Latch handle tips
- Area of contact between fuser release bail and roll
- All release arms areas of contact of fuser solenoid lever.

Use grease, p/n 1329301 to lubricate gear nos. 2,3,4,5,6, and 12. Use all the grease in the packet. Apply part of the grease, rotate the gears, and apply the rest. The teeth of gears 3, 4, and 5 should be completely coated.

Use grease, p/n 1384076 to lubricate:

- [A] Areas of contact between the two shafts and the grounding spring.
- Use grease, p/n 1383586 to lubricate: [B] on the duplex unit.

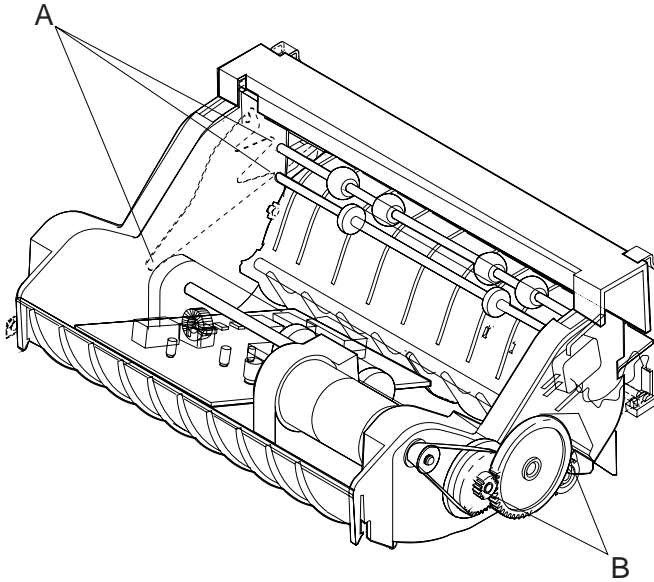

Printhead Window Cleaning Procedure

Do not use cleaning fluids on the printhead window. Do not use a bare cotton swab. The swab deposits lint on the window.

Note: The printhead window is a coated glass. Do not push too hard and scratch or break the glass.

1. Remove the print cartridge.
2. Fold a lint free cloth over a cotton swab.

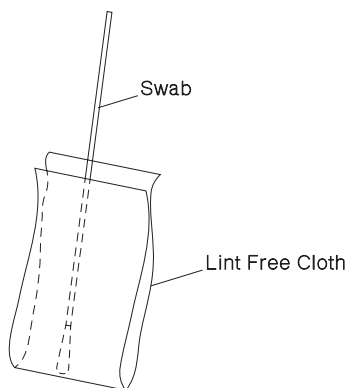

3. Open the shutter.
4. Insert the swab and cloth combination in the printhead window slot, then slide it left to right several times. Move the swab to a clean spot on the cloth and repeat the cleaning procedure. Do this procedure several times to make sure the window is clean.

Cleaning The Transfer Roller

Power off the printer. Power on and let it complete POST. Do this two to three times.

Scheduled Mechanical Maintenance

The operator panel will display the message “80 Scheduled Maintenance” at each 200K (100K for 12C) page count interval. It is necessary to replace the fuser assembly, transfer roller, d-roll, and lower redrive shaft assembly at this interval to maintain the print quality and reliability of the printer. These items are available as individual FRUs. They are also available as a maintenance Kit through the dealer options ordering channel.

After replacing the kit the maintenance count must be reset to zero to clear the “80 Scheduled Maintenance” message.

Parts Catalog

How To Use This Parts Catalog

- **SIMILAR ASSEMBLIES:** If two assemblies contain a majority of identical parts, they are broken down on the same list. Common parts are shown by one index number. Parts peculiar to one or the other of the assemblies are listed separately and identified by description.
- **AR:** (As Required) in the Units column indicates that the quantity is not the same for all machines.
- **NP:** (Non-Procurable) in the Units column indicates that the part is non-procurable and that the individual parts or the next higher assembly should be ordered.
- **NR:** (Not Recommended) in the Units column indicates that the part is procurable but not recommended for field replacement, and that the next higher assembly should be ordered.
- **R:** (Restricted) in the Units column indicates that the part has a restricted availability.
- **NS:** (Not Shown) in the Asm-Index column indicates that the part is procurable but is not pictured in the illustration.
- **INDENTURE:** The indenture is marked by a series of dots located before the parts description. The indenture indicates the relationship of a part to the next higher assembly. For example:

INDENTURE RELATIONSHIP OF PARTS

(No dot) MAIN ASSEMBLY

(One dot) o Detail parts of a main assembly

(One dot) o Subassembly of the main assembly

(Two dot) o o Detail part of a one-dot subassembly

(Two dot) o o Subassembly of a one-dot subassembly

Assembly 1: Covers

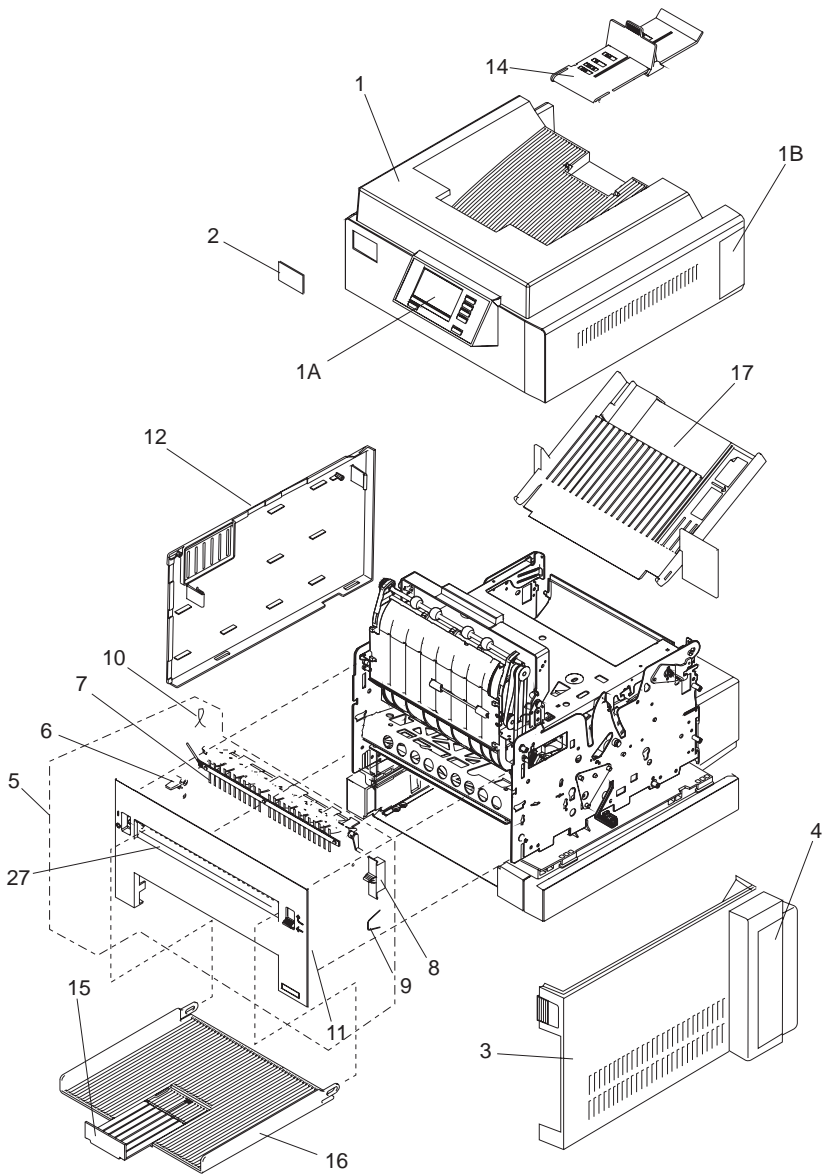

Asm-Index	Part Number	Units	Description
1-1	1325311	1	Top Cover 10R/12R/12C/10P
-1	1328204	1	Top Cover 12L/16L
NS	1329607	1	Kit, Stacker Spring 16L
-1A	1381017	1	Operator Panel Asm
-1B	1328207	1	Door, Top Cover 12L/16L
NS	1328453	1	Screw, Operator Panel
-2	1325135	1	Front Logo, 10R
-2	1325136	1	Front Logo, 12R
-2	1325137	1	Front Logo, 12L
-2	1325952	1	Front Logo, 12C
-2	1328511	1	Front Logo, 16L
-2	1419451	1	Front Logo, 10P
-2	1375923	1	Front Logo, 10R plus
-2	1375925	1	Front Logo, 12R plus
-2	1375992	1	Front Logo 12C plus
-2	1375927	1	Front Logo 12L plus
-2	1377417	1	Front Logo 16L plus
-3	1325115	1	Right Cover Asm 10R/12R/12L/12C
-3	1328208	1	Right Cover Asm 10P/16L
-4	1328210	1	Door, Right Cover
NS	1328329	1	Label, Door, Right Cover 10R/12R/12L/12C/ 16L
-5	1328186	1	Front Cover Asm
-6	1195318	1	On/Off Switch Lever
-7	1329070	1	Output Deflector
-8	1328473	1	Output Deflector Lever
-9		1	Spring, Deflector Lever, Parts Packet 1383316
-10	1058249	1	Spring, On-Off Actuator
-11	1183599	1	Spring, Front Cover Deflector
-12	1328185	1	Left Cover
-14	1325026	1	Paper Stop Asm,10R/12R/12C/10P
-14	1328509	1	Paper Stop Asm, 12L/16L
-15	1183536	1	Front Exit Slide
-16	1183538	1	Tray, Front Exit with slide

Assembly 1: Covers (Continued)

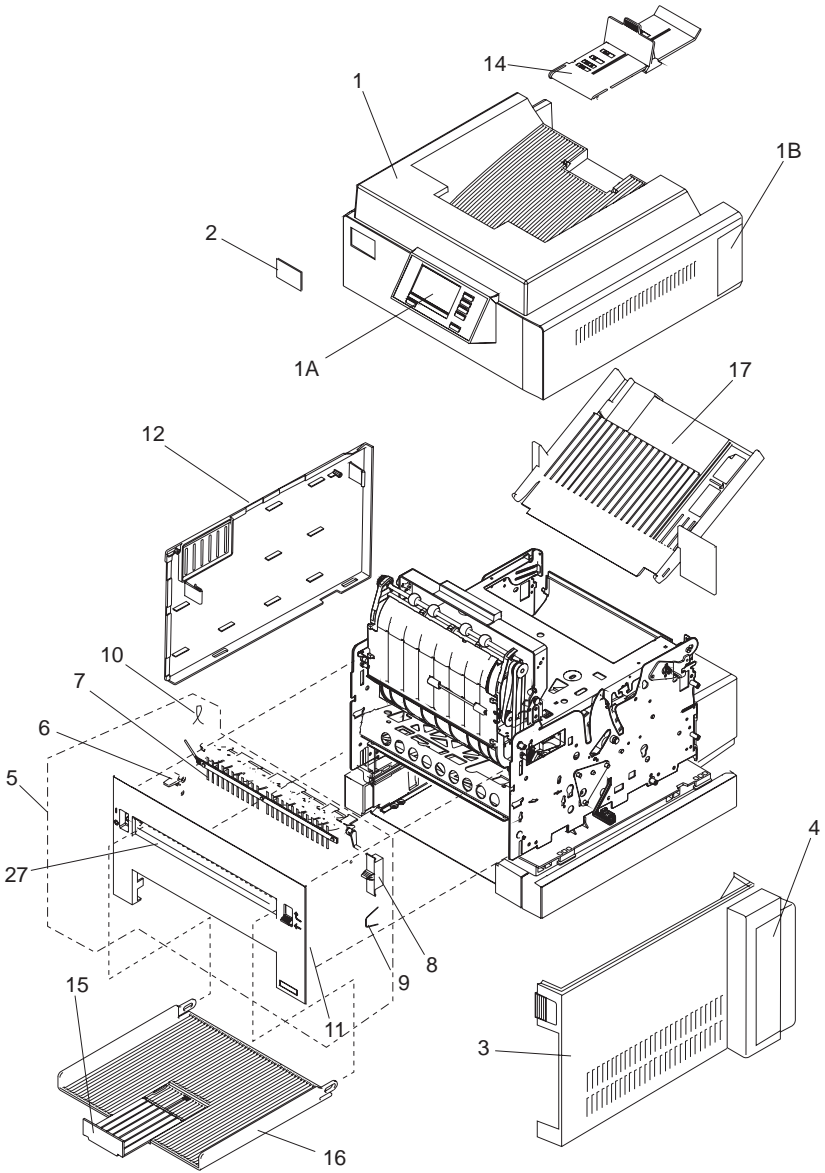

Asm-Index	Part Number	Units	Description
1-17	1328508	1	Manual Feed Tray with guide
NS		1	Screw (Deflector Spring Mtg.) Parts Packet 1383314
NS	1328482	1	Cover, Duplex mtg. slot
NS		1	Screw (Deflector Switch Mtg. plate) Parts Packet 1383314
-27	1328189	1	Front Exit Door

Assembly 2: Lower Frame

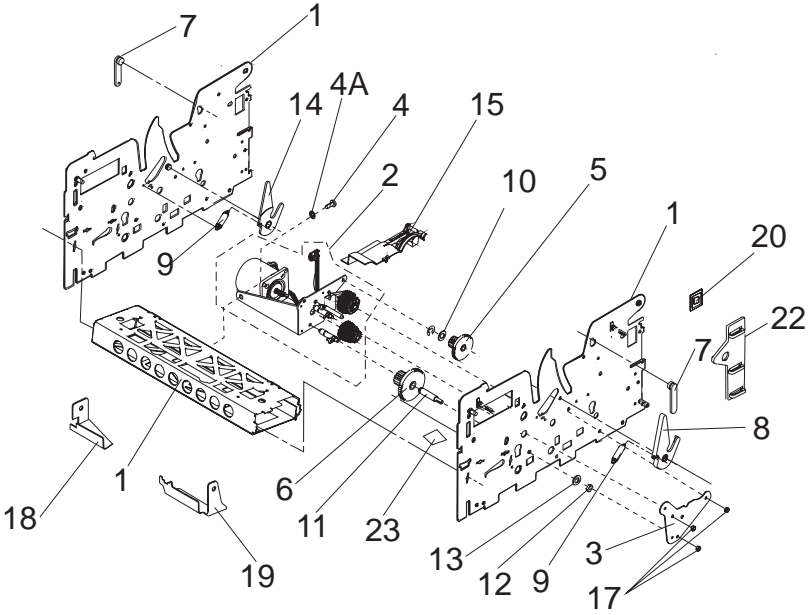

Asm-Index	Part Number	Units	Description
2-1	1381120	1	Lower Frame Assembly 10R/12R/12L/12C/16L/10P
-1	1381001	1	Lower Frame Assembly (16L below serial number 11-09885 U.S. & 11-10915 W.T.)
-2	1381046	1	Motor, Brkt. and Gear Asm. 10R
-2	1381047	1	Motor, Brkt. and Gear Asm. 12R/12L/12C
-2	1381121	1	Motor, Brkt. and Gear Asm. 16L
-2	1381002	1	Motor, Brkt. and Gear Asm. (16L below serial number 11-09885 U.S. & 11-10915 W.T.)
-2	1381049	1	Bracket and Gear Asm. 10R (W/O motor)
-2	1381122	1	Bracket and Gear Asm. 12R/12L/12C/16L (W/O motor)
-2	1381003	1	Bracket and Gear Asm. (W/O motor) (16L below serial number 11-09885 U.S. & 11-10915 W.T.)
-2	1381623	1	Motor, Brkt. and Gear Asm., 10P - includes Gear 6
-3	1325614	1	Plate Asm. Gear Box Mtg. 10R
-3	1329515	1	Plate Asm. Gear Box Mtg. 12R/12L/12C/16L
-3	1408672	1	Plate, Gear Box Mtg. 10P
-4	1328503	1	Screw, Motor Brkt. Mtg. (All except 10P)
-4A	1328441	1	Clip, Ground, Motor Mtg. (All except 10P)
NS	1623642	1	Mtg. Screw, motor (All except 10P)
NS	1623642	1	Mtg. Screw, Gear Asm. (All except 10P)
-5	1328244	1	Gear No. 6 (All except 10P)
-5A	1624875	1	Mtg. Screw, Gear # 6 (All except 10P)
-6	1328243	1	Gear No. 2
-7	1039391	2	Detent, Box
-8	1329013	1	Right Cartridge Latch
-9	1383316	1	Spring, Parts Packet
-10	1383314	1	Washer, Parts Packet
-11	1039271	1	Shaft, Gear 2
-12	1383314	1	Nut, Gear 2, PP
-13	1622347	1	Lockwasher, Gear 2
-14	1329144	1	Left Cartridge Latch
-15	1328245	1	Gear Train Cover (All except 10P)
-15	1408645	1	Gear Train Cover, 10P

Assembly 2: Lower Frame (Continued)

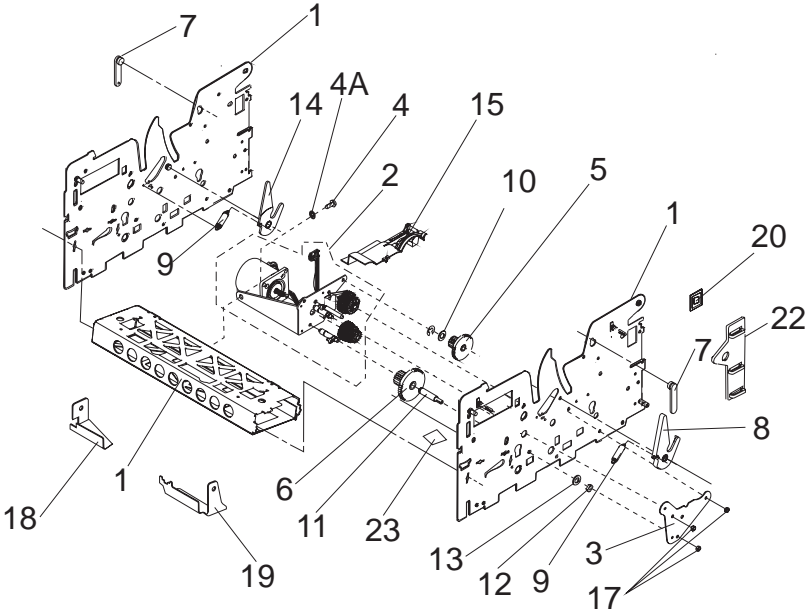

Asm-Index	Part Number	Units	Description
2-17	1383314	4	Nut, Motor Bracket Parts Packet
-17A	1383314	2	Screw, Motor Bracket Parts Packet, 10P
-18	1328428	1	LH Bracket, Duplex
-19	1328427	1	RH Bracket, Duplex
NS	1383314	1	Screw, Duplex Bracket Parts Packet
-20	1039476	1	Grommet, Printhead Cable
-21	1328181	1	Bracket, cover pivot
-22	1325282	1	Cable Clamp
-23	1408721	1	Guide, Cable, 10P
NS	1383314	1	Screw, Cable Clamp Parts Packet

Assembly 3: Upper Frame

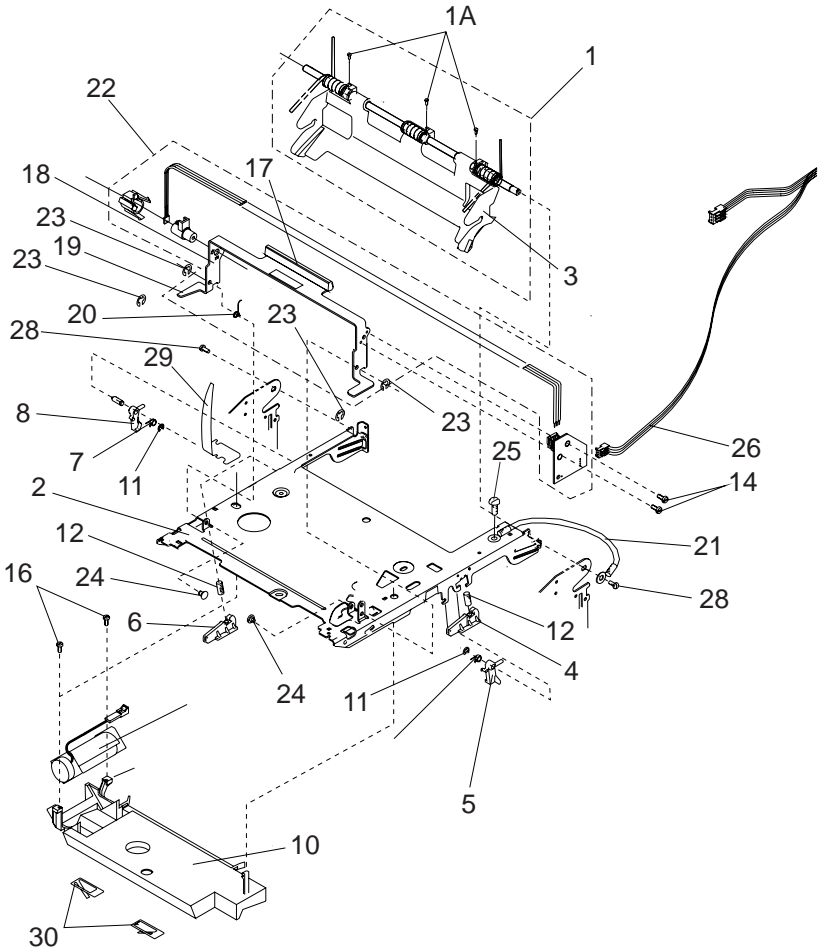

Asm-Index	Part Number	Units	Description
3-1	1325196	1	Cover Hinge Asm 10R/12R/12C/10P (does not include the load box)
-1	1381045	1	Cover Hinge Asm 12L/16L (does not include the load box)
-1A	1383314	1	Screw, Cover Hinge Parts Packet
-2	1325103	1	Upper Plate Asm 10R/12R/12C/10P
-2	1328218	1	Upper Plate Asm 12L/16L
-3	1328215	1	Cartridge Load Box 10R/12R/12C/12L/16L
-3	1402284	1	Cartridge Load Box, 10P
-4	1383315	1	Right Cam Button, Parts Packet
-5	1039693	1	Right Bellcrank
-6	1383315	1	Left Cam Button, Parts Packet
-7	1328220	1	Spring, Bellcrank
-8	1039692	1	Left Bellcrank
-9	1383998	1	Fan Asm
NS	1424481	1	Pad, Acoustic (Fan)
-10	1328222	1	Plenum Asm 12R/12L/12C/16L
-10	1325022	1	Plenum Asm 10R/10P
-11	1383315	1	Retainer, Parts Packet
-12	1383316	1	Spring, Parts Packet
NS	1383315	1	Retainer, Parts Packet
-14	1383314	1	Screw, Parts Packet
NS	1383314	1	Washer, Parts Packet
-16	1383314	1	Screw, Plenum Mtg., Parts Packet
-17	1328307	1	Grip, Handle
-18	1325049	1	Handle Latch 10R/12R/12C/10P
-18	1328217	1	Handle Latch 12L/16L
-19	1328308	1	Sleeve
-20	1325108	1	Spring, Handle
-21	1383313	2	Ground Strap, Parts Packet
-22	1381004	1	Output Bin Sensor Assembly (handle mounted) 12L/16L
-23	1383316	1	Retainer, E-Clip, Parts Packet
-24	1383315	1	Pivot, Handle--Parts Packet
-25	1383314	2	Screw, Parts Packet

Assembly 3: Upper Frame (continued)

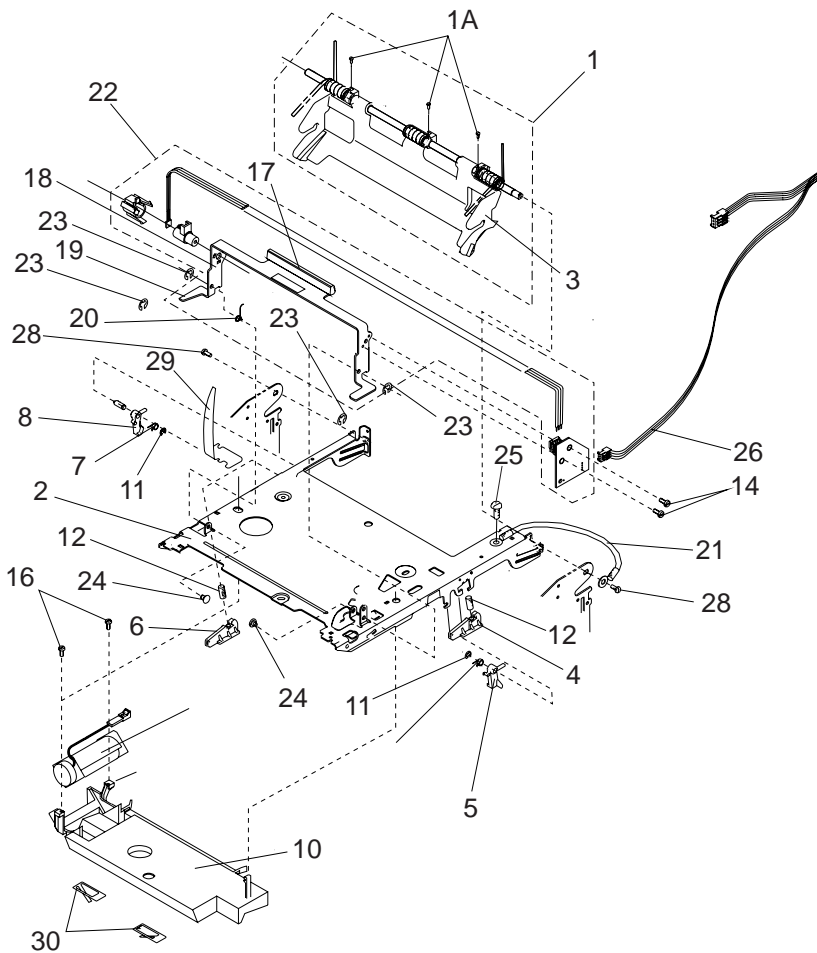

Asm-Index	Part Number	Units	Description
3-26	1381099	1	Cable, Output Bin/Operator Panel 12L(handle mounted sensor)
-26	1381134	1	Cable, Output Bin/Operator Panel 16L(handle mounted sensor)
-26	1381095	1	Cable, Operator Panel 12C/12R/10R/10P
-28	1383314	2	Screw, Shaft Mtg., Parts Packet
-29	1325138	1	Spring, Redrive 10R/12R/12C/10P
-30	1325067	2	Spring, Plenum 10R/10P
-30	1328467	2	Spring, Plenum 12R/12L/12C/16L

Assembly 4: Printhead

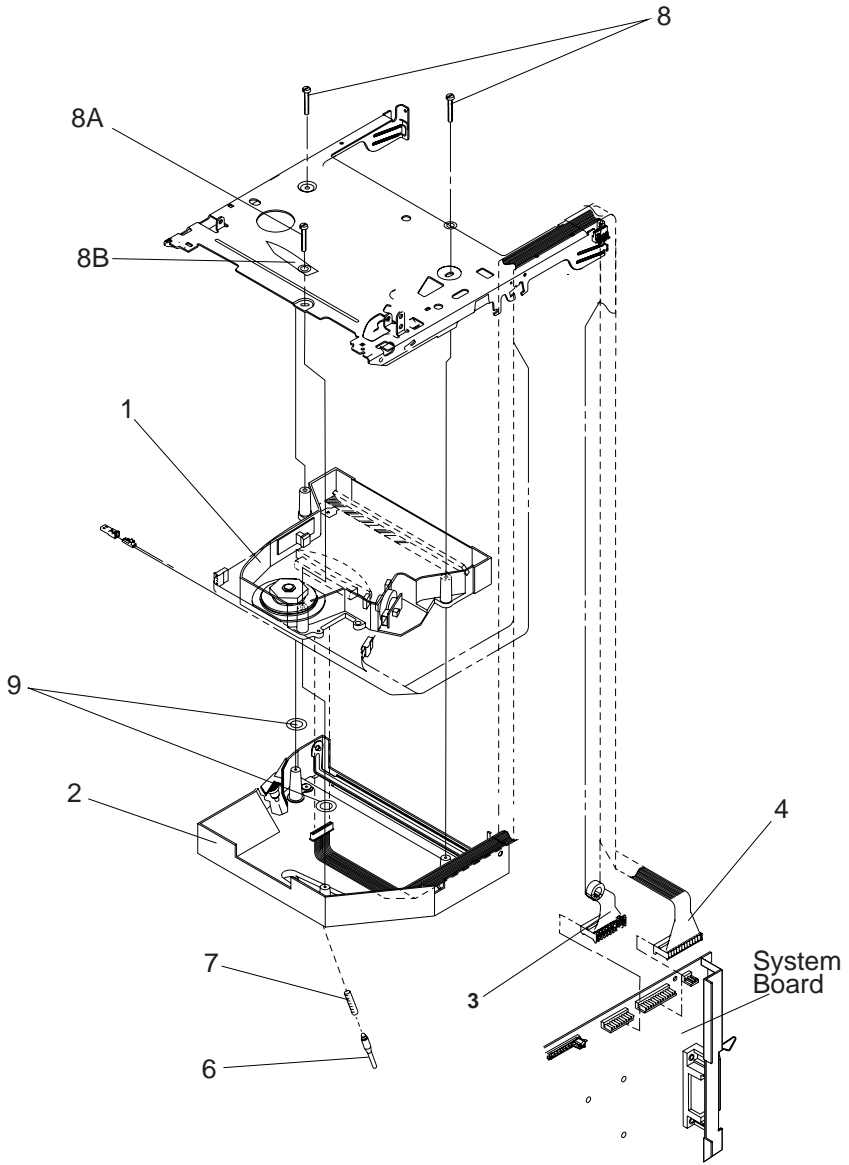

Asm-Index	Part Number	Units	Description
4-1	1381624	1	Printhead 10P
-1	1381005	1	Printhead 10R/12R/12C/12L/16L
-2	1328431	1	Printhead Shroud Assembly
-3	1325017	1	Cable, Fan/Mirror Motor
-4	1325018	1	Cable, hsync/Laser
NS	1038199	1	Cable, Tie
-6	1383315	1	Pin, Parts Packet
-7	1383316	1	Spring, Parts Packet
-8	1383314	2	Screw, Printhead Mtg., Parts Packet
-8A	1383314	1	Screw, Hex Headed Parts Packet
-8B	1383314	1	Pointer, Parts Packet
-9	1383315	1	Retainer, Parts Packet

Assembly 5: Paper Feed

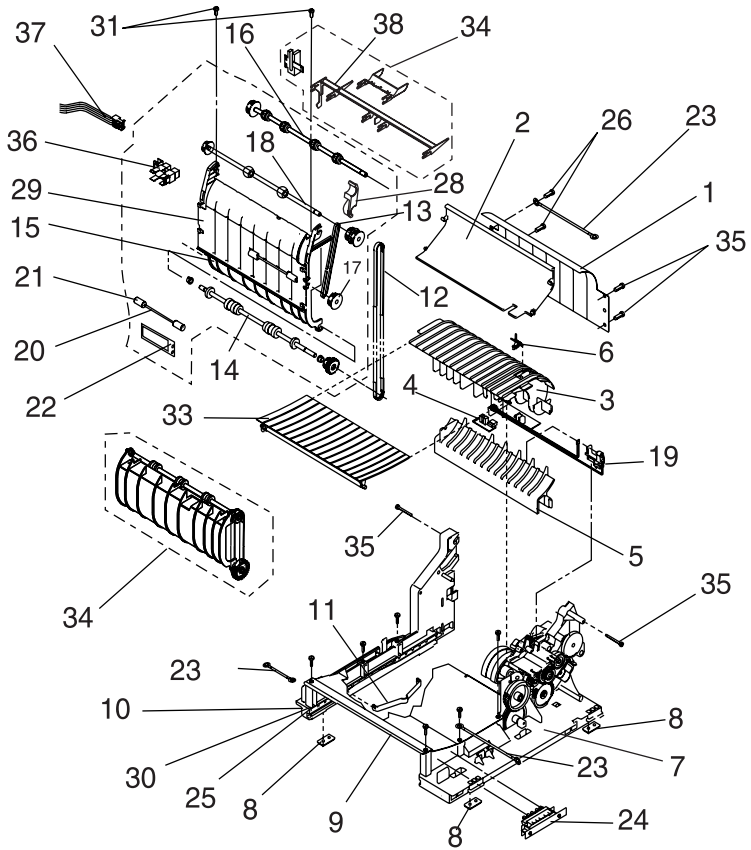

Asm-Index	Part Number	Units	Description
5-1	1039101	1	Outer Deflector
-2	1183597	1	Upper Deflector
-3	1381670	1	Inner Deflector with Roller
-4	1381636	1	Input Sensor Board 10P
-4	1383430	1	Input Sensor Board 10R/12R/12C/12L/16L
-5	1039102	1	Lower Deflector 10R/12R/12L/16L
-5	1408859	1	Lower Deflector 10P/12C
-6	1383315	1	Flag, Input Sensor, Parts Packet
-7	1328385	1	Right Rail Asm (With Gears) 10R/12R/12C/12L/16L
-7	1328314	1	Right Rail Asm (Without Gears)
-8	1039170	1	Machine Pad 10R/12R/12C/10P
-9	1328648	1	Toner Shield
-10	1328317	1	Left Frame
-11	1039175	1	Tray Frame Spring
-12	1042211	1	Belt, Redrive 10R/12R/12C/10P
-12	1328192	1	Belt, Redrive 12L/16L
-13	1328193	1	Belt, Auxiliary 12L/16L
-14	1039058	1	Shaft Asm, Lower Redrive 10R/10P
-14	1328172	1	Shaft Asm, Lower Redrive 12R/12L/12C/16L
-15	1042205	1	Deflector, Redrive 10R/10P/12R/12C
-15	1328168	1	Deflector, Redrive 12L/16L
-16	1042206	1	Shaft Asm, Upper Redrive
-17	1328169	1	Shaft Asm, Auxiliary Shaft 12L/16L
-18	1042207	1	Shaft Asm, Middle Redrive 10R/10P
-18	1328173	1	Shaft Asm, Middle Redrive 12R/12C/12L/16L
-19	1381073	1	Toner Sensor
-20	1328323	1	Shaft 12L/16L
-21	1328322	1	Roller, backup 12L/16L
-22	1328321	1	Spring, backup 12L/16L
-23	1383313	2	Jumper, Ground, Parts Packet
-24	1381015	1	Paper Size Sensor Asm
-25	1183244	1	Arm, Tray Frame

Assembly 5: Paper Feed (Continued)

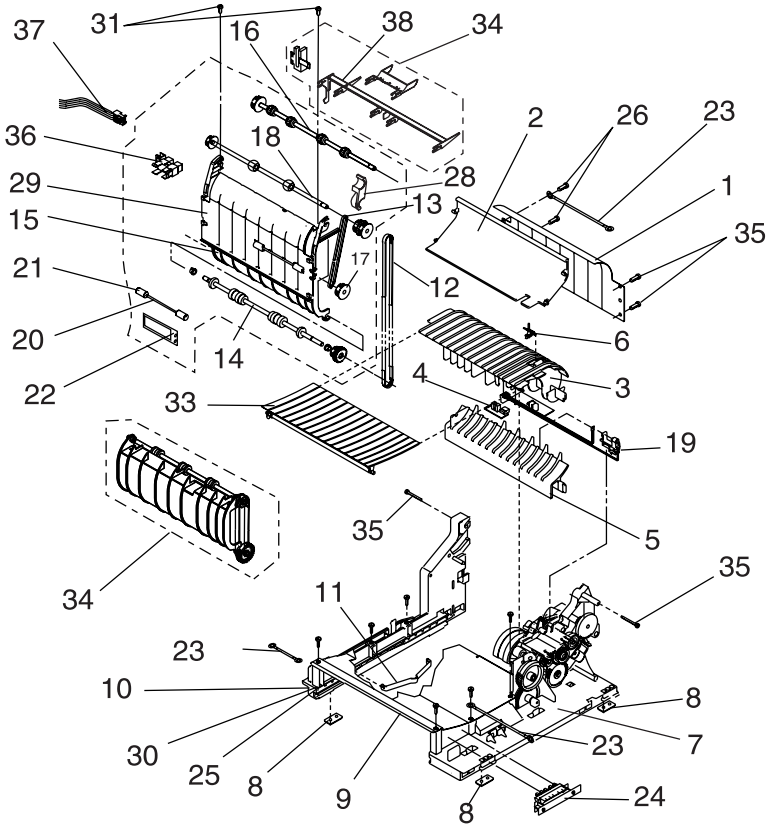

Asm-Index	Part Number	Units	Description
5-27	1328452	1	Deflector, Paper 10R/12R/12C/12L/16L/10P
NS	1328450	1	Spring, Shaft Grd. 12L/16L
-28	1381617	1	Kit, Anti-Squeak Bearing 10P/10R/12R/12C
-28	1381618	1	Kit, Anti-Squeak Bearing 12L/16L
-29	1328381	1	Outer Redrive Shield 12L/16L
NS	1383314	1	Screw Backup Spring Mtg., Parts Packet
-30	1183245	1	Spring, Arm Tray Bias
-31	1383314	1	Screw, Redrive Mtg., Parts Packet
-33	1328298	1	Guide, Fuser Input
-34	1328167	1	Redrive Assembly 12L/16L,With Handle-Mounted Bin Sensor
-34	1381527	1	Redrive Assembly 12L/16L,With Redrive-Mounted Bin Sensor
-34	1042230	1	Redrive Assembly 10R/10P
-34	1325515	1	Redrive Assembly 12R/12C
-35	1383314	1	Screw Parts Packet
NS	1328345	1	Spring, Bias, Transfer Housing
-36	1381298	1	Output Bin Sensor 12L/16L, redrive mounted sensor
-37	1376284	1	Cable, Output Bin/Op Panel 12L/16L, redrive mounted sensor
-38	1381567	1	Kit, Bail, Minibail, and Guide 12L/16L, redrive mounted sensor

Assembly 6: Paper Feed Alignment Gears

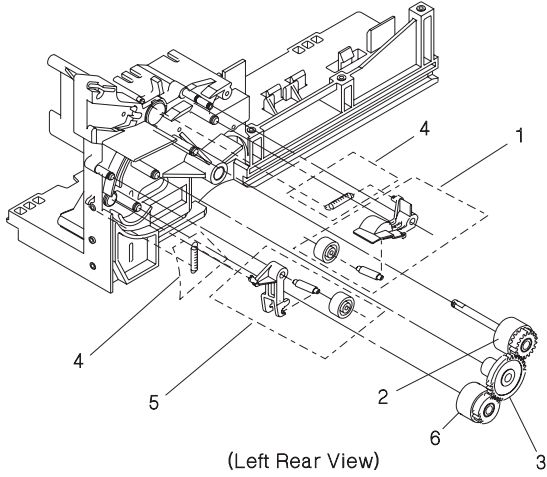

Asm-Index	Part Number	Units	Description
6-1	1328383	1	Bellcrank, Metering 10P/10R/12R/12L/16L
-1	1409238	1	Bellcrank, Metering 12C
-		1	o Shaft
-		1	o Bellcrank
-		1	o Roll
-		1	o Thrust Washer
-2	1381145	1	Kit, Prealigner and Metering Rollers
-3	1039278	1	Gear, Idler, Prealigner
-4	1383316	1	Spring, Prealigner and Metering Bellcranks, Parts Packet
-5	1328384	1	Bellcrank, Prealigner 10P/10R/12R/12L/16L
-		1	o Shaft
-		1	o Roll
-		1	o Bellcrank
-		1	o Thrust washer
-5	1402336	1	Bellcrank, Prealigner 12C
NS	1383580	1	Anchor Repair Kit (Metering)
NS	1383908	1	Anchor Repair Kit (Prealigner)

Assembly 7: Paper Feed Drive

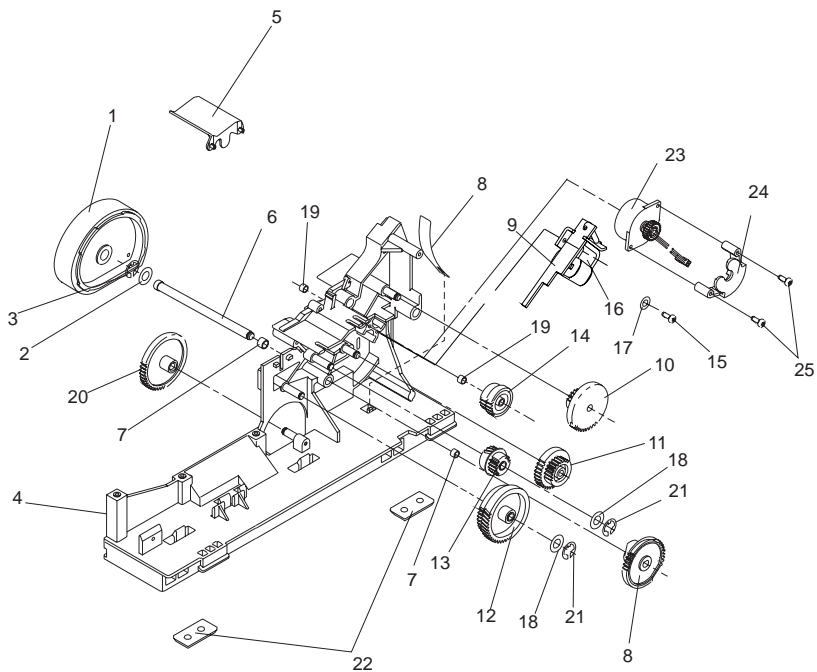

Asm-Index	Part Number	Units	Description
7-1	1328311	1	D-Roller Asm 10R/12R/12L/16L
-1	1408705	1	D-Roller Asm, 10P/12C
-2	1328279	1	Washer, Thrust
-3	1126832	1	Clip, D-roll
-4	1328385	1	Rail Assembly, Right (With gears)10R/12R/ 12C/12L/16L
-4	1328314	1	Rail Assembly, Right (W/O gears)
-5	1328313	1	Shield, D-Roll
-6	1328454	1	Shaft, D-Roll with Gear 11, 10R/12R/12C/12L/ 16L
-6	1408482	1	Shaft, D-Roll with Gear 11, 10P
-7	1383315	1	Bushing, Parts Packet
-8	1383316	1	Spring, Gear Advance Parts Packet 10R/12R/ 12C/12L/16L
-9	1383433	1	Clutch Magnet Asm 10R/12R/12C/12L/16L
-10	1383318	1	Gear No. 14, Sheet Feed, Parts Packet
-11	1383318	1	Gear No. 9, Parts Packet 10R/12R/12C/12L/ 16L
-11	1408259	1	Gear No. 9, 10P
-12	1383318	1	Gear No. 7, Parts Packet
-13	1383318	1	Gear No. 8, Parts Packet
-14	1383318	1	Gear No. 10, Parts Packet
-15	1383314	1	Screw, Clutch Mag. Mtg., Parts Packet 10R/ 12R/12C/12L/16L
-16	1383316	1	Spring, Magnet Arm, Parts Packet 10R/12R/ 12C/12L/16L
-17	1383314	1	Washer, Parts Packet 10R/12R/12C/12L/16L
-18	1383314	1	Washer, Thrust, Parts Packet
-19	1383315	1	Bushing, Gear 10, Parts Packet
-20	1383318	1	Gear 13, Parts Packet
-21	1383315	1	Clip, Parts Packet
-22	1039170	1	Machine Pad
-23	1381306	1	Torquer Motor, 10P
-24	1408243	1	Adapter, Torquer Motor, 10P
-25	1381663	2	Screw, Torquer, Parts Packet

Assembly 8: Standard Paper Tray (200 sheet)

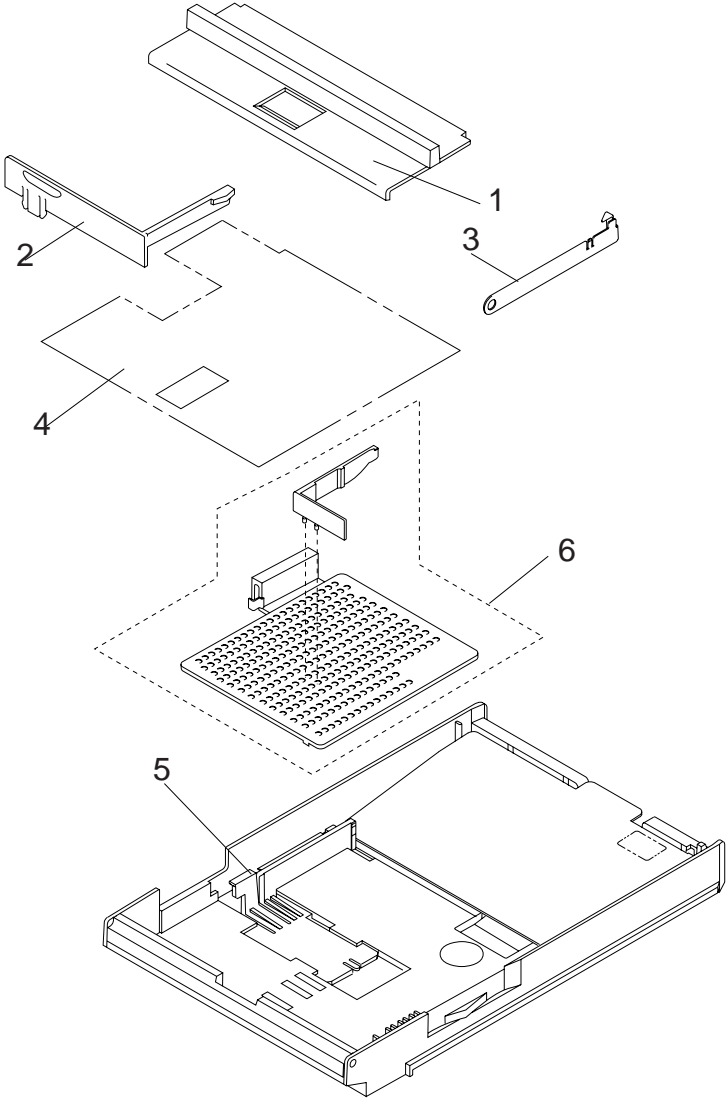

Asm-Index	Part Number	Units	Description
8-	1183260	1	Paper Tray Assembly, 11 in. (200-sheet)
-	1183276	1	Paper Tray Assembly, 14 in. (200-sheet)
-	1183367	1	Heavy Duty Paper Tray Assembly, 11 in. (200-sheet)
-	1058272	1	Heavy Duty Paper Tray Assembly, 14 in. (200-sheet)
-	1183376	1	Paper Tray Assembly, A5
-1	1183266	1	11 in. Cover
-1	1183275	1	14 in. Cover
-2	1183163	1	Paper Stop
-3	1408567	1	Corner Buckler
-4	1183329	1	Liner, 11 in.
-4	1183330	1	Liner, 14 in.
-5	1039562	1	Adjustable Guide
-6	1058486	1	Universal Paper Tray Adapter

Assembly 9: Paper Tray (500-Sheet)

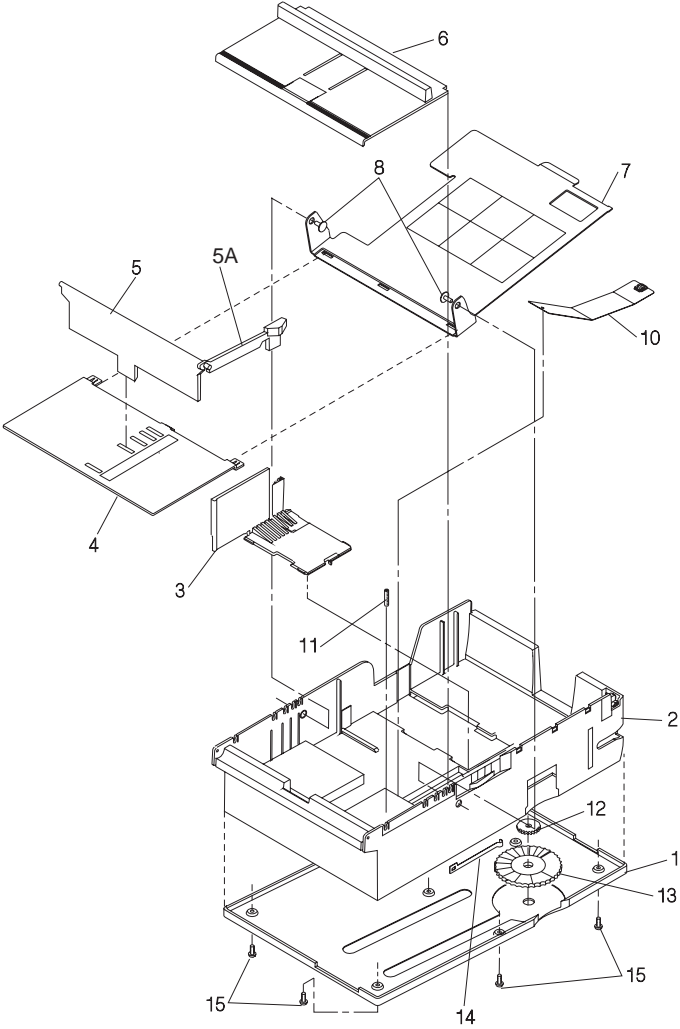

Asm-Index	Part Number	Units	Description
9-	1195837	1	Paper Tray Assembly, 11 in.
-	1195831	1	Paper Tray Assembly. 14 in.
-1	1183801	1	Bottom Cover 11 in.
-1	1183804	1	Bottom Cover 14 in.
-2	1183357	1	Base 11 in.
-2	1183359	1	Base 14 in.
-3	1039582	1	Paper Guide
-4	1408851	1	Slide 11 in.
-4	1408882	1	Slide 14 in.
-5	1183262	1	Paper Stop
-5A	1183298	1	Slider, Paper Stop
-6	1183266	1	Cover 11 in.
-6	1183275	1	Cover 14 in.
-7	1195835	1	Pivot Plate, with label
-8	1383385	1	Retainer, Parts Packet
-10	1424558	1	Spring Assembly
-11	1383385	1	Setscrew, Parts Packet
-12	1383390	1	Thumb Wheel Gear, Parts Packet
-13	1383390	1	Wheel, Parts Packet
-14	1039597	1	Detent Spring
-15	1383385	1	Screw, Parts Packet

Assembly 10: Base for Paper Drawer (500-Sheet)

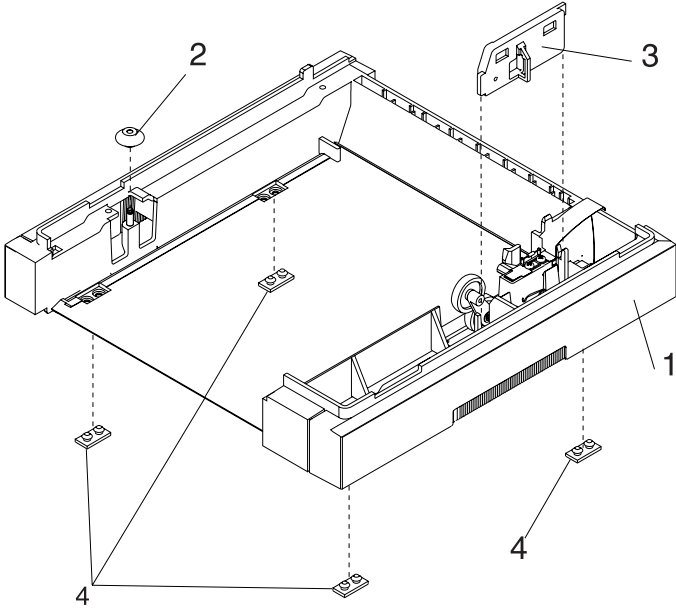

Asm-Index	Part Number	Units	Description
10-1	1328194	1	Housing
-2	1039558	1	Roll
-3	1328197	1	Plate Assembly, Gear
-4	1039170	1	Pad, Machine
NS	1328674	1	Clip, Ground

Assembly 11: Optional Paper Drawer (500-Sheet)

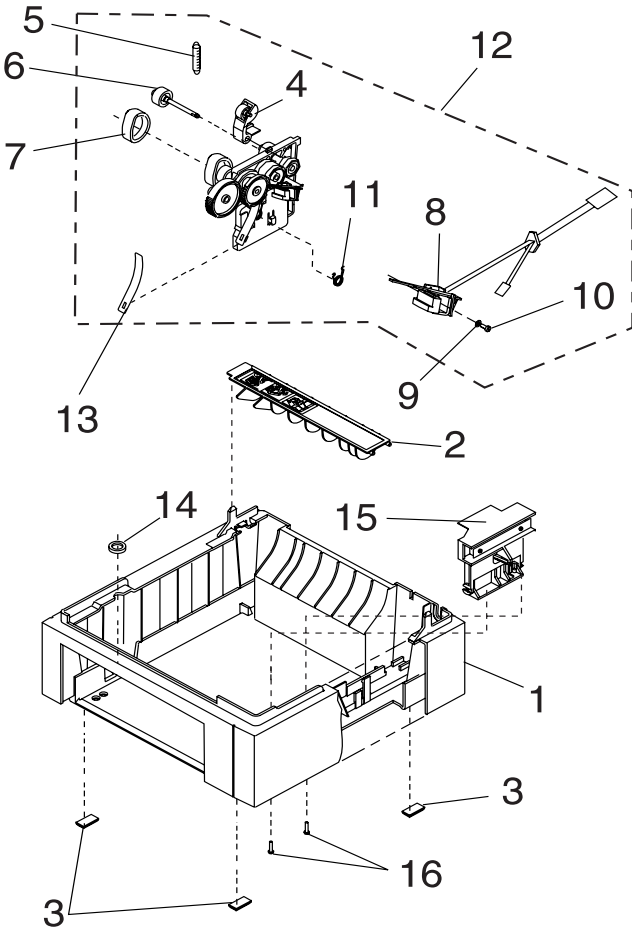

Asm-Index	Part Number	Units	Description
11-1	1183342	1	Base Assembly
-2	1328630	1	Deflector
-3	1039170	1	Feet
-4	1039596	1	Bellcrank Assembly
-5	1383316	1	Spring, Bellcrank, Parts Packet
-6	1039603	1	Drive Roller
-7	1039540	1	D-Roller Tire
-8	1383925	1	Paper Feed Magnet
-9	1383385	1	Washer, Parts Packet
-10	1383385	1	Screw, Parts Packet
-11	1383385	1	Spring, Parts Packet
-12	1381622	1	Drive Assembly
-13	1383316	1	D-Roller Bias Spring, Parts Packet
-14	1039558	1	Roller
-15	1183299	1	Switch Assembly
-16	1383314	1	Screws, Parts Packet

Assembly 12: Fuser

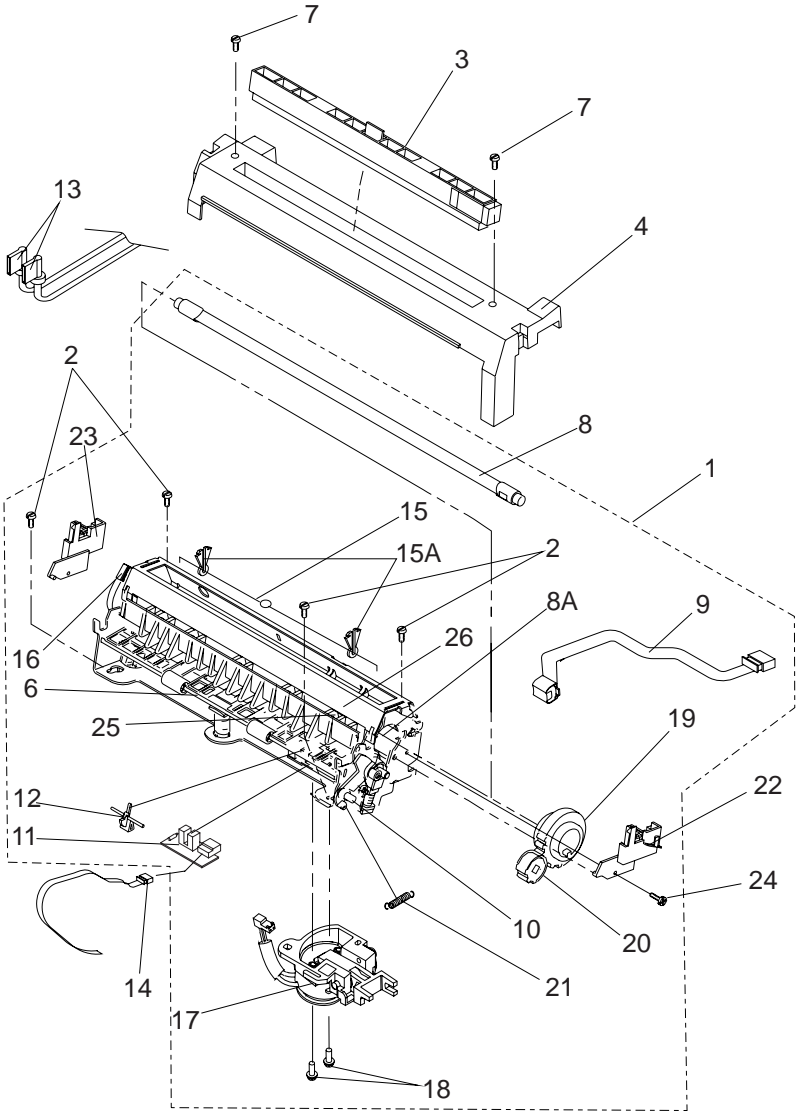

Asm-Index	Part Number	Units	Description
12-1	1381082	1	Fuser and Lamp 110V 10R
-1	1381083	1	Fuser and Lamp 110V 12R/12L
-1	1381521	1	Fuser and Lamp 110V 12C
-1	1381084	1	Fuser and Lamp 220V 10R
-1	1381085	1	Fuser and Lamp 220V 12R/12L
-1	1381522	1	Fuser and Lamp 220V 12C
-1	1381010	1	Fuser and Lamp 110V 16L
-1	1381038	1	Fuser and Lamp 220V 16L
-1	1381626	1	Fuser and Lamp 110V 10P
-1	1381627	1	Fuser and Lamp 220V 10P
-1	1381679	1	Fuser and Lamp, Low Pressure 110V 10R
-1	1381678	1	Fuser and Lamp, Low Pressure 220V 10R
-2	1383314	1	Screw, Fuser Asm, Parts Packet
-3	1380785	1	Fuser Wiper Assembly (supply item) 10R/12R/12C/12L/16L
-3	1382287	1	Fuser Wiper Assembly (supply item) 10P
-4	1039315	1	Fuser Cover 10R/10P
-4	1328132	1	Fuser Cover 12R/12L/12C/16L
-6	1038717	1	Spring Redrive Exit
-7	1383314	1	Screw, Parts Packet
-8	1383311	1	Fuser Lamp 110V 10R/12R/12L. Install lamp with color-coded end away from gear.
-8	1381523	1	Fuser Lamp 110V 12C/10P. Install lamp with color-coded end away from gear.
-8	1383324	1	Fuser Lamp 220V 10R/12R/12L. Install lamp with color-coded end away from gear.
-8	1381524	1	Fuser Lamp 220V 12C/10P. Install lamp with color-coded end away from gear.
-8	1381011	1	Fuser Lamp 110V 16L. Install lamp with color-coded end away from gear.
-8	1381037	1	Fuser Lamp 220V 16L. Install lamp with color-coded end away from gear.

Assembly 12: Fuser (Continued)

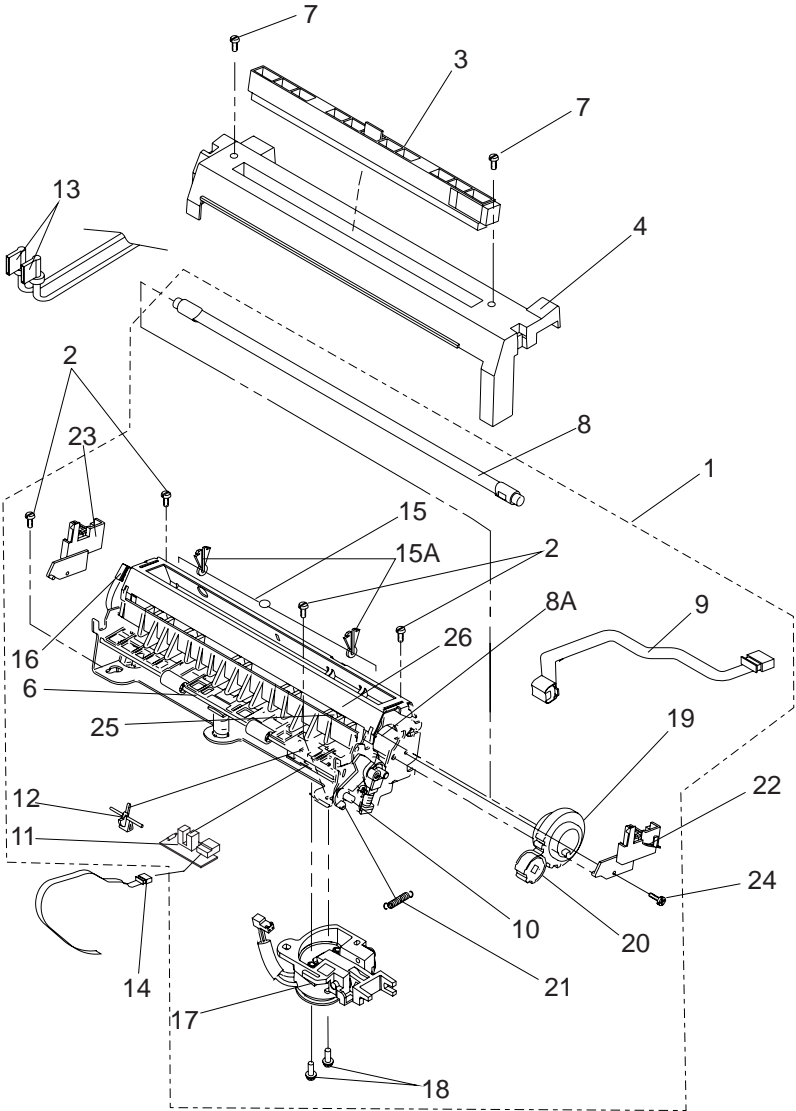

Asm-Index	Part Number	Units	Description
12-8A	1381086	1	Hot Roll Assembly 10R
-8A	1381076	1	Hot Roll Assembly 12R/12L/16L
-8A	1381146	1	Hot Roll Assembly 12C
-8A	1383322	1	Hot Roll Asm, 10P
NS	1039305	1	Backup Roll 10R/12R/12L/16L
NS	1329928	1	Backup Roll, 10P
-9	1381012	1	Thermistor Sensor Asm 10R/12R/12C/12L/16L
-9	1381637	1	Thermistor Sensor Asm, 10P
-10	1328458	1	Redrive Idle Arm Asm, 12R,12L,12C,16L
-10	1376367	1	Redrive Idle Arm Asm, 10R/10P
-11	1381687	1	Paper Exit Bd Asm
-12	1383315	1	Flag, Parts Packet
-13	1039481	1	Fuser Power Cable
-14	1381537	1	Cable, Fuser/Front Cover Exit Sensor
-15	1381155	1	Thermal Fuse Asm
-15A	1039328	2	Clips, Thermal Fuse 10R/10P
-15A	1328134	2	Clips, Thermal Fuse 12R/12L/16L
-16	1039311	1	Bail Handle
-17	1381018	1	Fuser Solenoid Asm 12R/12L/16L
-18	1383314	1	Screw, Fuser Solenoid Mtg., Parts Packet
-19	1039251	1	Gear No. 1, Hot Roll 10R/10P
-19	1328124	1	Gear No. 1, Hot Roll 12R/12L/12C/16L
-20	1383317	1	Gear 18T Redrive, Parts Packet
-21	1383316	1	Spring, Redrive Idler Parts Packet
-22	1328437	1	Contact Asm, Right Lamp
-23	1328438	1	Contact Asm, Left Lamp
-24	1383314	1	Screw, Mtg., Parts Packet
-25	1039316	1	Detack Fingers
-26	1039317	1	Detack Finger springs

Assembly 13: Electronics

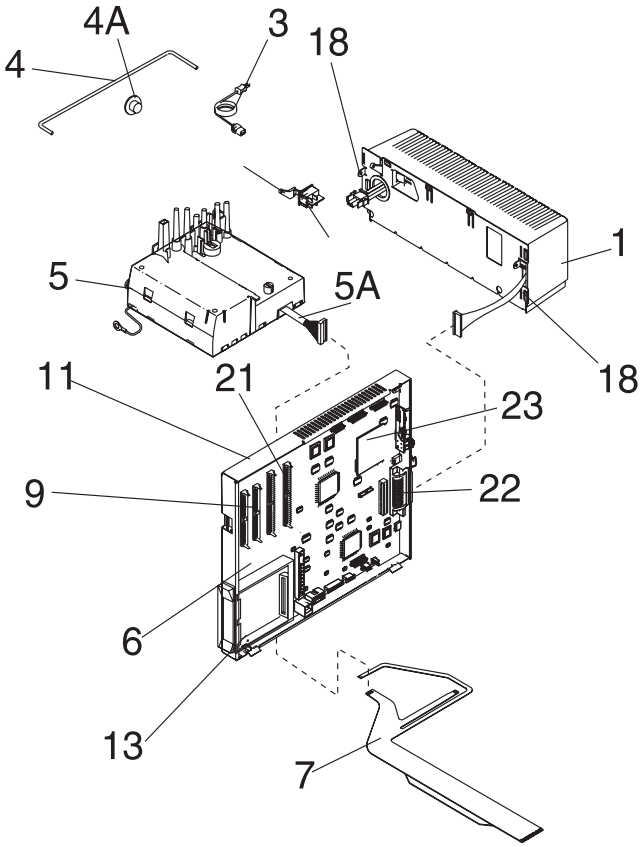

Asm-Index	Part Number	Units	Description
13-1	1383974	1	LV Power Supply 110V 10R/12R/12L/12C
-1	1383975	1	LV Power Supply 220V 10R/12R/12L/12C
-1	1381014	1	LV Power Supply 110V 16L
-1	1381039	1	LV Power Supply 220V 16L
-1	1383981	1	LV Power Supply 100V 10R/12R/12L/12C
-1	1381643	1	LV Power Supply 110V, 10P
-1	1381644	1	LV Power Supply 220V, 10P
NS	1328463	1	Fuse, LVPS SB 12A 110V 16L/10P
NS	1328464	1	Fuse, LVPS 6.3A 220V 16L/10P
NS	1035151	1	Fuse, LVPS SB 10A 110V 10R/12R/12L/12C
NS	1051604	1	Fuse, LVPS 4A 220V 10R/12R/12L/12C
-3	1342514	1	Power Cord Set, U.S./Canada/Mexico/Central and South America/ Saudi Arabia (LV)/Peru
-3	1342530	1	Power Cord Set, Germany/France/Spain/Norway/Finland/the Netherlands/Austria/Belgium/Brazil/Greece/Luxembourg/Portugal/Sweden/Turkey/Indonesia/ Saudi Arabia (HV)
-3	1342532	1	Power Cord Set, S. Africa
-3	1342533	1	Power Cord Set, Switzerland
-3	1342534	1	Power Cord Set, Chile/Italy
-3	1342535	1	Power Cord Set, Denmark
-3	1342536	1	Power Cord Set, New Zealand/Australia/Argentina/Paraguay
-3	1342537	1	Power Cord Set, Israel
-3	1342543	1	Power Cord Set, UK/Malaysia/Singapore
-4	1039467	1	Rod, on/off
-4A	1058266	1	Support, Rod on/off
-5	1381390	1	HV Power Supply 10R/12R/12C/12L/16L
-5	1381645	1	HV Power Supply 10P
-5A	1381653	1	Cable, HV Power Supply 10P
-6	1381515	1	System Board 10R
-6	1381517	1	System Board 12R/12L
-6	1381504	1	System Board 12C
-6	1381519	1	System Board 16L
-6	1381578	1	System Board 10P
NS	1408063	1	Cable, Erase Lamps/Input Sensor Board, 10P

Assembly 13: Electronics (Continued)

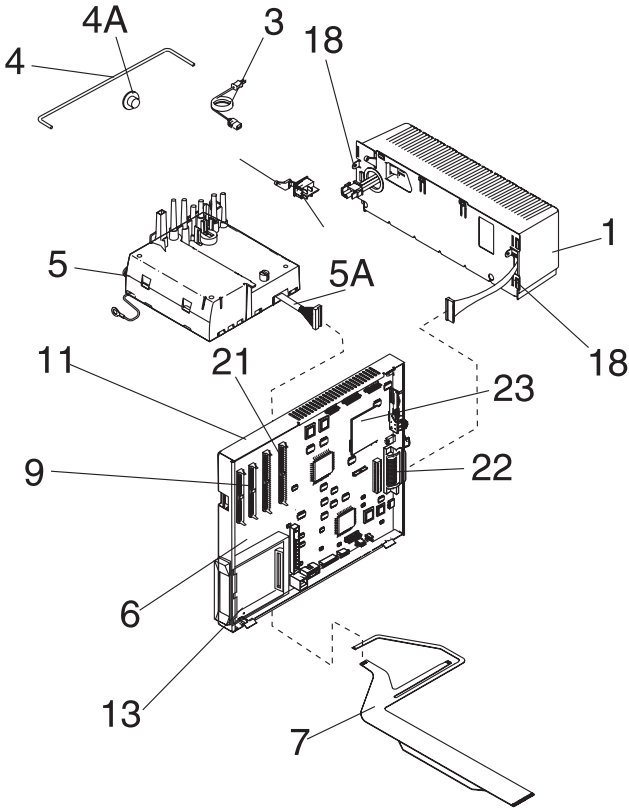

Asm-Index	Part Number	Units	Description
13-7	1328291	1	Cable, HVPS/Input Sensor Board 10R/12R/12C/12L/16L
-9	1321882	1	DRAM SIMM 4MB 12R/12L
-9	1328589	1	DRAM SIMM 2MB 10R/10P
-11	1325436	1	Inner EMC Shield 10R/12R/12L/12C
NS	1325434	1	Outer EMC Shield 10R/12R/12L/12C
-11	1328337	1	Inner EMC Shield 16L
-11	1419453	1	Inner EMC Shield 10P
NS	1328338	1	Outer EMC Shield 16L
-13	1325106	1	Guide, Font Card 10R/12R/12L/12C
-13	1328988	1	Guide, Font Card 16L
NS	1383314	1	Washer, Parts Packet
NS	1328969	2	Nut, Card Mtg.
NS	1325489	4	Standoff, Card Gnd, 10R/12R/12L/12C
NS	1328281	2	Standoff, Internal Threads
NS	1328280	4	Standoff, Card Gnd, 16L, External Threads
NS	1195319	2	Standoff, INA or DC to DC, plastic
NS	1383315	2	Standoff, Sys. Bd., plastic, Parts Packet
NS	1383315	2	Standoff, Sys. Bd., plastic, Parts Packet
NS	1383314	1	Screw, HVPS Mtg., Parts Packet
-18	1383314	1	Screw, LVPS Mtg., Parts Packet
-19	1383513	1	Switch On/Off
-20	1039456	1	Switch Pivot
-21	1381513	1	ROM SIMM 10R
-21	1381484	1	ROM SIMM 12R/12L/12C
-21	1381509	1	ROM SIMM 16L
-21	1381628	1	ROM SIMM 10P
-21	1376388	1	ROM SIMM, 10R, 4039 plus
-21	1376389	1	ROM SIMM, 12R/12L, 4039 plus
-21	1376390	1	ROM SIMM, 16L, 4039 plus
-22	1325197	1	Serial cable 10R/12R/12L/12C
-22	1328644	1	Serial cable 16L
NS	1328647	1	Screw, serial cable
-23	1381097	1	DC to DC convertor 10R/12R/12L/12C

Assembly 14: Transfer Roll

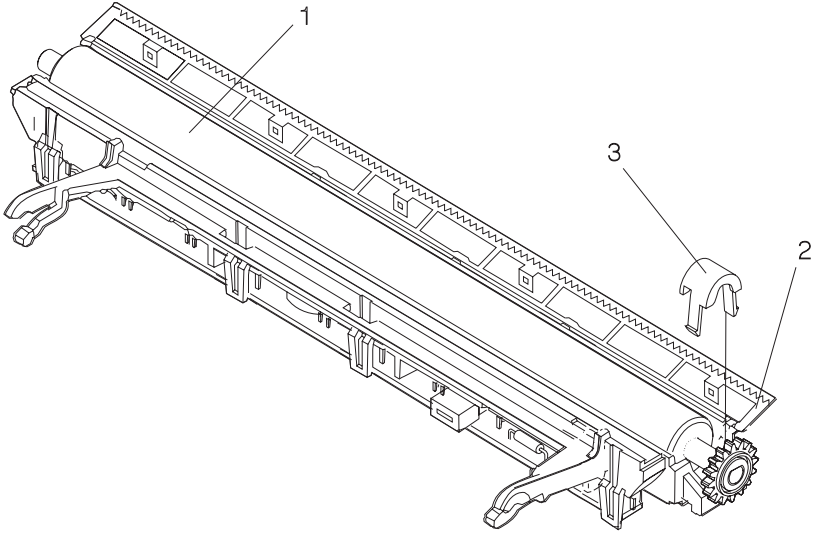

Asm-Index	Part Number	Units	Description
14-1	1381008	1	Roll Asm, Transfer
-2	1381007	1	Housing, Transfer 10R/12R/12C/12L/16L
-2	1381652	1	Housing, Transfer 10P ("sawtooth" not present on 10P)
		1	o Rear Lens Asm, Erase
		1	o Front Lens Asm, Erase
		1	o Contact, Transfer Roll
		1	o Lamp Asm, Erase
-3	1328356	1	Cover, Clip Bearing

Assembly 15: Duplex Option

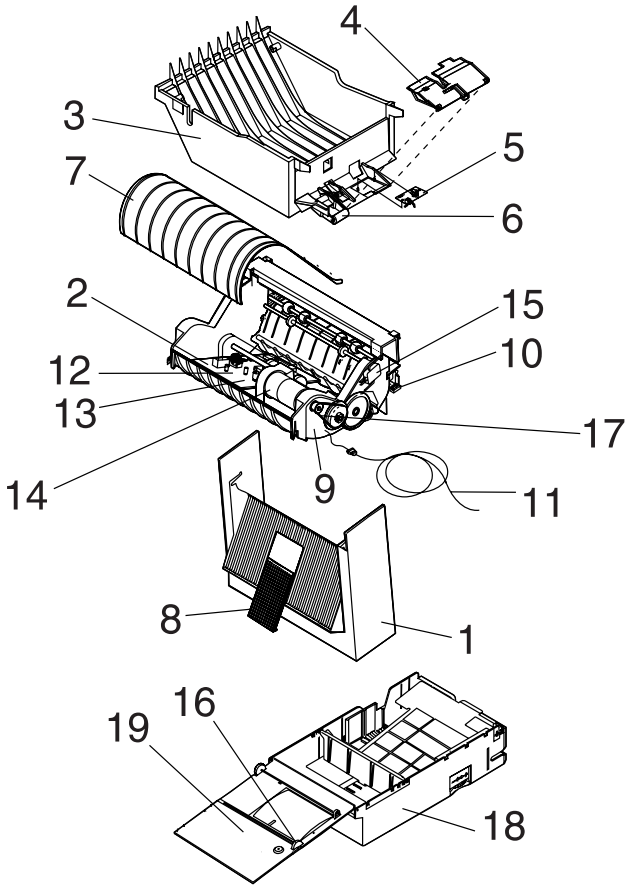

Asm-Index	Part Number	Units	Description
15-1	1381019	1	Top Cover Asm (with fan)
-2	1381006	1	Duplex System Card
-3	1381020	1	Bottom Cover
-4	1326137	1	Exit Sensor Cover
-5	1381021	1	Exit Sensor Asm
-6	1408906	1	Bellcrank
-7	1408905	1	Table Cover (Floor)
-8	1326001	1	Paper Stop/Slide
-9	1381023	1	Gear Block Frame Asm
-10	1381024	1	Input Sensor Card
-11	1326041	1	Duplex System Cable
-12	1326042	1	Cable, Stepper Motor
-13	1326043	1	Cable, Sensor
-14	1381025	1	Paper Feed Motor (DC)
-15	1326113	1	Switch Asm Cover Open
-16	1038708	1	Belt Paper Tray
-17	1326064	1	Belt Paper Drive
-18	1381033	1	Tray Asm 300 w/Top Cover 12L/16L
-18	1381582	1	Tray Asm 130 w/Top Cover 10R/12R/10P
-19	1381034	1	Top Cover Paper Tray
NS	1381035	1	Gear Parts Pack
NS	1381048	1	Flag Parts Pack (4)

**Assembly 16: Envelope+ and 100-Sheet
Auxiliary Feeder**

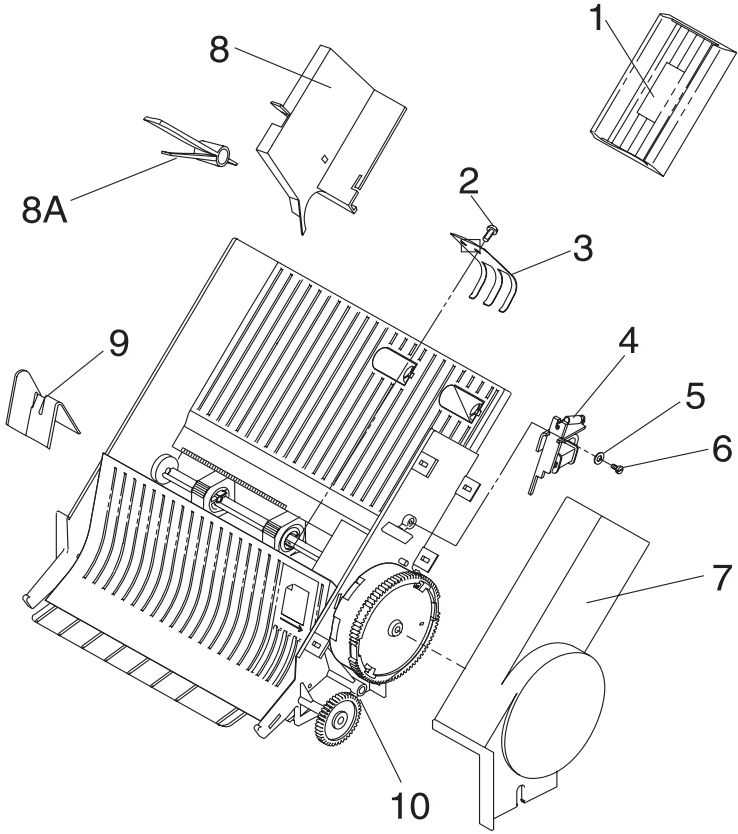

Asm-Index	Part Number	Units	Description
16-	1183151	1	Envelope+ Feeder
-	1183966	1	100-Sheet Auxiliary Feeder
-1	1183226	1	Weight Assembly
-2	1622529	1	Screw
-3	1039615	1	Spring
-4	1383944	1	Magnet Assembly
-5	1622303	1	Washer
-6	1622536	1	Screw, Mtg
-7	1183587	1	Cover, Right
-8	1183155	1	Guide, Large
-8A	1183160	1	Latch, Guide
-9	1328459	1	Guide, Small
-10	1183273	1	Spring, Override Lever (100-Sheet Auxiliary Feeder Only)
NS	1383934	1	Roller Pack (Envelope+ Feeder Only)
NS	1383935	1	Roller Pack (100-Sheet Auxiliary Feeder Only)

Assembly 17: Options

Asm-Index	Part Number	Units	Description
17-2	1328586	1	1MB Flash SIMM
-3	1328585	1	2MB Flash SIMM
-4	1376461	1	4MB Flash SIMM
-5	1328589	1	2MB DRAM SIMM
-6	1321882	1	4MB DRAM SIMM
-7	1321883	1	8MB DRAM SIMM
-8	13A0339	1	4MB DIMM
-9	13A0340	1	8MB DIMM
-10		1	Option Cards
-	1381050	1	o INA-LocalTalk
-	1402209	1	o INA-Ethernet 10Base2, low memory
-	1402207	1	o INA-Token Ring, low memory
-	1402208	1	o INA-Ethernet 10BaseT, low memory
-	1402219	1	o INA-Ethernet 10Base2, high memory
-	1402217	1	o INA-Token Ring, high memory
-	1402218	1	o INA-Ethernet 10BaseT, high memory
-	13A0294	1	o INA-SCS
-	13A0295	1	o INA-IPDS
-	13A0296	1	o 9 pin-to-Twinax cable, SCS or IPDS
-	13A0297	1	o 9 pin-to-BNC cable, SCS or IPDS
-	13A0298	1	o 9 pin-to-9 pin set up cable
-	1328563	1	o Screw, INA ground
-9	1325231	1	Font Card Adapter 10R/12R/12L/12/C
-10	1329037	1	Font Cartridge Adapter 16L
-11	1381096	1	DC to DC Network Power Card
-12	1329498	1	Hard Disk, 40MB, 16L
-	1425267	1	Hard Disk, 40MB, 10P
13	1363110	1	Serial Adapter, 10P

Assembly 18: Miscellaneous

Asm-Index	Part Number	Units	Description
-	1319128	1	Parallel Wrap Plug
-	1329048	1	Serial Wrap Plug
-	1383313	1	Cables/Jumpers parts packet
-	1383314	1	Fasteners parts packet
-	1383315	1	Clips parts packet
-	1383316	1	Springs parts packet
-	1383317	1	Gears (1-6) parts packet
-	1383318	1	Gears (7-14) parts packet
-	1381145	1	Metering and Prealigner rolls parts packet
-	1383385	1	Paper Tray parts packet
-	1383390	1	Paper Tray parts packet
-	1329301	1	Grease, 2g
-	1384076	1	Grease, conductive 1 oz.
-	1383586	1	Grease, damping, 1 oz.
-	9900692	1	Grease, IBM #23
-	1280443	1	Oil, IBM #10 4 oz.
-	1381035	1	Duplex Gears parts packet
-	1381048	1	Duplex Flags parts packet
-	1381963	1	Twinax/serial debug cable
-	1381964	1	Coax/serial debug cable

Index

A

- abbreviations 4
- auto clean 35
- auto clean delay 35
- auto clean frequency 35

B

- background 13
- banding 13
- black page 15
- blank page 16
- blurred or fuzzy print 17
- button test 41

C

- connector locations 103
- covers
 - assembly 128
 - removal 64

D

- dead machine 17
- defaults 36
- developed image test 36
- diagnostic aids
 - alphabetical 35
 - grouped 34
- diagnostics mode 33
- disk test/clean 36
- drive motor removal 70
- D-roll assembly removal 69
- duplex feed 1 test 37
- duplex feed 2 test 38
- duplex option
 - assembly 168

- bottom cover/entry sensor card removal 100
- exit card and cover removal 100
- problems 18
- system card and motor removal 102
- top cover/table cover removal 99

E

- electronics assembly 162
- envelope enhance 39
- envelope print test 39
- Envelope+ and 100-sheet auxiliary feeder assembly 170
- Envelope+ feeder adjustments
 - envelope restraint spring 54
 - magnet 55
- error codes 5
- error log 39
- ESD-sensitive parts 53
- exit sensor removal 87

F

- fan
 - cable locations 115
 - 927 error 19
- fan/redrive removal 72
- frame
 - lower frame assembly 132
 - lower frame assembly removal 83
 - upper frame assembly 136
 - upper frame removal 97
- fuser
 - assembly 158
 - drive gear backlash adjustment 56
 - input guide removal 74
 - lamp removal 76

- removal 74
- solenoid adjustment 58
- solenoid removal 77
- thermistor removal 78
- 920,921, or 922 error 20
- 923 error 21
- fuser temperature 40
- fuser theory 20
- fuser/sensor cable removal 94

G

- gear train locations 104

H

- honeycomb 21
- horizontal void or streak 22
- HVPS locations 105

I

- input sensor removal 82

L

- LAN
 - information 48
 - problems 23
- LCD test 42
- light print 23
- lower frame
 - assembly 132
 - assembly removal 83
- lubrication specifications 121
- LVPS
 - cover removal 85
 - removal 84

M

- maintenance approach 3
- maintenance kit count 41

- major assembly locations 103
- memory test 41
- mirror motor cable locations 115

N

- network
 - connections and checks 47
 - wrap tests 24
- network card
 - 977 errors 24

O

- operator panel
 - problems 25
 - removal 86
- operator panel/output bin sensor cable
 - handle-mounted outbin sensor 116
 - redrive-mounted outbin sensor 117
- option card removal 86
- optional paper feed
 - magnet adjustments 60
- options
 - assembly 172
 - available 2
- output bin sensor 24

P

- page count 42
- paper drawer
 - base assembly, 500-sheet 154
 - optional (500-sheet) assembly 156
- paper feed
 - alignment gears assembly 146
 - assembly 142
 - drive assembly 148
 - magnet adjustments 59

- magnet assembly removal 88
- rollers removal 89
- paper feed problem
 - base printer 26
 - duplex unit 27
 - Envelope+ feeder 28
 - 100-sheet auxiliary feeder 28
 - 500-sheet second tray 26
- paper feed test 42
- paper size
 - sensing problem 29
 - switch removal 90
- paper tray
 - (500-sheet) assembly 152
 - standard (200 sheet) assembly 150
- parts catalog 127
 - how to use the catalog 127
- permanent page count 43
- power-on self test (POST) 11
- preventive maintenance 121
- print contrast 43
- print registration adjustments 63
- print test page 43
- print test 1 44
- print test 2 44
- print test 3 45
- printer ground strap locations 119
- printhead
 - assembly 140
 - cable locations 114
 - diagnosis 28
 - removal 91
 - skew adjustments 61, 62
- printhead window
 - cleaning procedure 124

Q

- quick disk test 45
- quick test 45

R

- random marks 31
- regularly spaced marks 30
- removals 64
- repair information 53
- residual image 30

S

- safety inspection guide 121
- scheduled mechanical maintenance 125
- sensor test 46
- serial interface option 48
- skew
 - all edges 31
 - top and bottom only 31
- stalled (diamonds on display) 31
- symptom table 12
- system board
 - connector locations 108, 110, 112
 - removal 92
- system cable
 - locations 107
 - removal 94

T

- test page 43
- toner sensor removal 95
- tools required 4
- torquer motor removal 94
- transfer roller
 - assembly 166
 - cleaning 124
 - removal 68
- transfer roller housing
 - locations 106
 - removal 96
- transfer test 43

U

upper frame
assembly 136
removal 97

V

vertical void or streak 31

W

warm-up time 40
wrap tests 47

Z

Zif connector removal 98

Numeric

100-sheet auxiliary feeder
paper restraint spring
adjustment 54

Readers Comment Form

You may use this form to communicate your comments about this publication, with the understanding that Lexmark may use or distribute whatever information you supply in any way it believes appropriate without incurring any obligation to you.

1. Did you find the book well organized?
Yes No
2. Was the content of the book accurate and complete?
Yes No
3. Was the book easy to use?
Yes No
4. What can we do to improve the book?

5. What is your job title?

Questions or comments about supplies, service, applications, and so on will slow response time considerably. Please refer those questions or comments to your authorized dealer or point of purchase.

Note: Please direct all requests for copies of publications to your point of purchase. Publications are not stocked at the location to which this form is addressed.

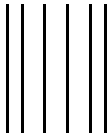

NO POSTAGE
NECESSARY
IF MAILED
IN THE
UNITED STATES

BUSINESS REPLY MAIL

FIRST CLASS MAIL PERMIT NO. 2659 LEXINGTON, KY

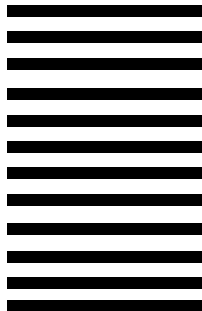

POSTAGE WILL BE PAID BY ADDRESSEE

LEXMARK INTERNATIONAL INC
DEPARTMENT D22A BUILDING 035 3
740 NEW CIRCLE ROAD NW
LEXINGTON KY 40511 9954



Fold Here

Cut Along Line

Tape

Please Do Not Staple

Tape